

# **SERVICE MANUAL**

**Models**

**RGV2800, RGV4100,  
RGV6100**

**Generators**

PUB-GS1277  
Rev. 4/99

# CONTENTS

<i>Section</i>	<i>Title</i>	<i>Page</i>
<b>1.</b>	<b>SPECIFICATIONS</b>	<b>1</b>
<b>2.</b>	<b>PERFORMANCE CURVES</b>	<b>3</b>
<b>3.</b>	<b>FEATURES</b>	<b>5</b>
3-1	BRUSHLESS ALTERNATOR	5
3-2	CONDENSER TYPE VOLTAGE REGULATOR	5
3-3	OIL SENSOR	5
3-4	QUIET OPERATION	5
3-5	NO RADIO NOISE	5
3-6	LARGE FUEL TANK	5
3-7	RUGGED TUBULAR FRAME	5
3-8	COMPACT AND LIGHT WEIGHT	5
3-9	MINIMAL MAINTENANCE	6
3-10	LONG-LIFE DURABILITY	6
<b>4.</b>	<b>GENERAL DESCRIPTION</b>	<b>7</b>
4-1	EXTERNAL VIEW	7
4-2	CONTROL PANEL	8
4-3	LOCATION of SERIAL NUMBER and SPECIFICATION NUMBER	9
<b>5.</b>	<b>CONSTRUCTION AND FUNCTION</b>	<b>10</b>
5-1	CONSTRUCTION	10
5-2	FUNCTION	10
5-3	GENERATOR OPERATION	16
5-4	OIL SENSOR	19
<b>6.</b>	<b>SAFETY PRECAUTIONS</b>	<b>22</b>
<b>7.</b>	<b>RANGE OF APPLICATIONS</b>	<b>23</b>
<b>8.</b>	<b>MEASURING PROCEDURES</b>	<b>26</b>
8-1	MEASURING INSTRUMENTS	26
8-2	AC OUTPUT MEASURING	29
8-3	DC OUTPUT MEASURING	29
8-4	MEASURING INSULATION RESISTANCE	30
<b>9.</b>	<b>CHECKING FUNCTIONAL MEMBERS</b>	<b>32</b>
9-1	VOLTMETER	32
9-2	AC RECEPTACLES	32
9-3	No-FUSE BREAKER	32

<i>Section</i>	<i>Title</i>	<i>Page</i>
9-4	STATOR .....	33
9-5	ROTOR ASSEMBLY .....	34
9-6	CONDENSER .....	34
9-7	DIODE RECTIFIER .....	35
9-8	OIL SENSOR .....	36
<b>10.</b>	<b>DISASSEMBLY AND ASSEMBLY .....</b>	<b>37</b>
10-1	PREPARATION and PRECAUTIONS .....	37
10-2	DISASSEMBLY PROCEDURES .....	37
10-3	ASSEMBLY PROCEDURES .....	38
10-4	CHECKING, DISASSEMBLY and REASSEMBLY of the FRONT PANEL .....	46
<b>11.</b>	<b>TROUBLESHOOTING .....</b>	<b>51</b>
11-1	NO AC OUTPUT .....	53
11-2	AC VOLTAGE IS TOO HIGH OR TOO LOW .....	55
11-3	AC VOLTAGE IS NORMAL AT NO-LOAD, BUT THE LOAD CANNOT BE APPLIED .....	56
11-4	NO DC OUTPUT .....	57
11-5	IDLE CONTROL(OPTIONAL EQUIPMENT) .....	58
<b>12.</b>	<b>WIRING DIAGRAM .....</b>	<b>61</b>
<b>Troubleshooting Manual RGV4101/RGV6101.....</b>		<b>64</b>
<b>1.</b>	<b>SPECIFICATIONS.....</b>	<b>64</b>
<b>2.</b>	<b>GENERATOR TROUBLE SHOOTING.....</b>	<b>65</b>
2-1	No AC output.....	65
2-2	AC voltage is too high or too low.....	67
2-3	AC voltage is normal at No-load, but the load cannot be applied.....	68
2-4	No DC output.....	69
2-5	Idle control (Optional equipment).....	71
<b>3.</b>	<b>RANGE OF APPLICATIONS.....</b>	<b>74</b>
<b>4.</b>	<b>WIRING DIAGRAM.....</b>	<b>77</b>

**NOTE :** As for the servicing information on engine protion, please refer to the EH17-2, EH25-2 and EH34 engine service manual.

# 1. SPECIFICATIONS

Model		RGV2800	RGV4100
<b>ENGINE</b>	Type	Brushless, Self Exciting, 2-Pole, Single Phase	
	Frequency	60 Hz	
	Maximum Output	2800 W	4100 W
	Rated Output	2300 W	3600 W
		120V	120V
	Voltage	19.2A	30.0A
		120V/240V	120V/240V
	Rated Current	19.2A/9.6A	30.0A/15.0A
	Power Factor	1.0	
	DC Output	12 V-8.3 A (100 W)	
Voltage Regulator	Condenser Type		
<b>ALTERNATOR</b>	Type	Air-Cooled 4-Cycle, Overhead Valve Gasoline Engine	
	Model	EH17-2D	EH25-2D
	Displacement	172 cm <sup>3</sup> (10.50 cu. in.)	251 cm <sup>3</sup> (15.32 cu. in.)
	Rated Output	4.0 HP / 3600 rpm	6.4 HP / 3600 rpm
	Fuel	Automobile Gasoline	
	Fuel Tank Capacity	3.17 U.S. gal. (12 liters)	4.38 U.S. gal. (16.6 liters)
	Rated Continuous Operation	9.0 hours	7.0 hours
	Oil Capacity	0.17 U.S. gal. (0.65 liters)	0.36 U.S. gal. (1.0 liters)
	Starting System	Recoil Starter	Recoil Starter and Optional Electric Starter
	Dimensions (L x W x H)	22.0 x 16.3 x 19.4 in. (560 x 415 x 493 mm)	24.4 x 16.9 x 21.7 in. (620 x 430 x 552 mm)
Dry Weight	106 lbs. (48 kg)	132 lbs. (140 lbs.)* / 60 kg (63.5 kg)*	

\* Electric starter motor is available as option.

<b>Model</b>		<b>RGV6100</b>	
<b>ENGINE</b>	Type	Brushless, Self Exciting, 2-Pole, Single Phase	
	<b>AC</b>	Frequency	60 Hz
		Maximum Output	5800 W
		Rated Output	4800 W
	Voltage	Rated Current	40A/20A
		Rated Voltage	120V/240V
	Power Factor	1.0	
	DC Output	12 V-8.3 A (100 W)	
	Voltage Regulator	Condenser Type	
	Type	Air-Cooled 4-Cycle, Overhead Valve Gasoline Engine	
Model	EH34D		
<b>ALTERNATOR</b>	Displacement	338 cm <sup>3</sup> (20.63 cu. in.)	
	Rated Output	8.0 HP / 3600 rpm	
	Fuel	Automobile Gasoline	
	Fuel Tank Capacity	5.67 U.S. gal. (21.5 liters)	
	Rated Continuous Operation	7.0 hours	
	Oil Capacity	0.32 U.S. gal. (1.2 liters)	
	Starting System	Recoil Starter and Optional Electric Starter	
	Dimensions (L x W x H)	26.8 x 18.5 x 24.8 in. (680 x 470 x 630 mm)	
	Dry Weight	172 lbs. (180 lbs.)* / 78 kg (81.5 kg)*	

\* Electric starter motor is available as option.

## 2. PERFORMANCE CURVES

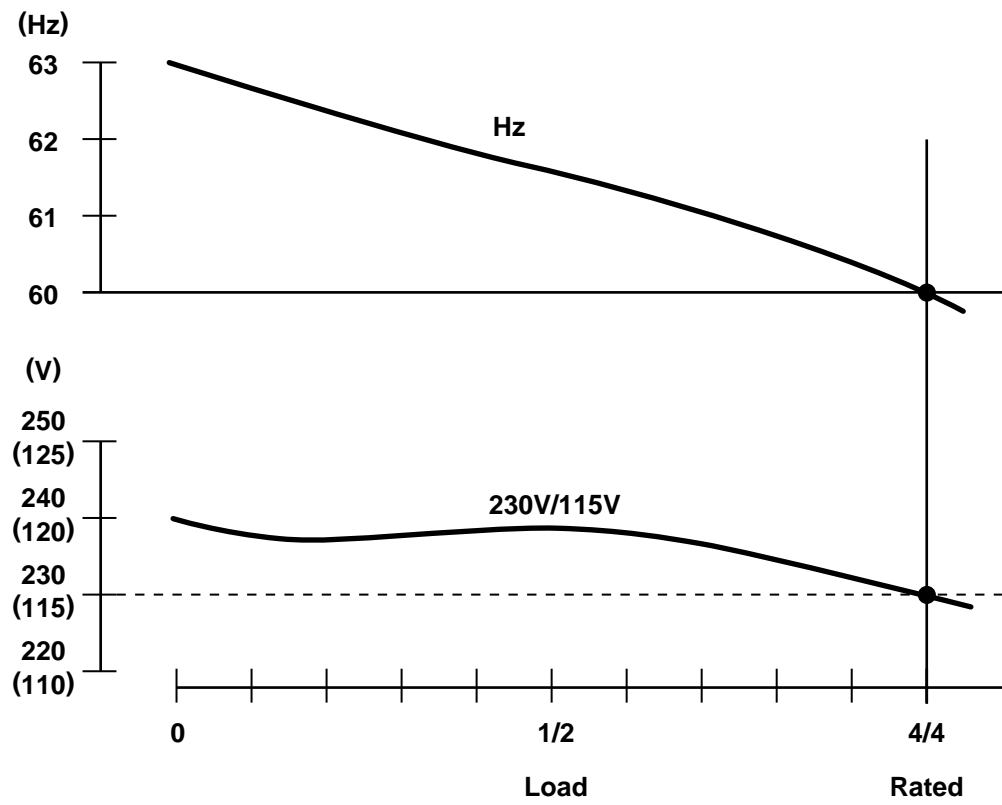

## DC OUTPUT

DC Voltage ..... 12 V

DC Ampere ..... 8.3 A

DC output ..... 100 W

The voltage curve shown in the left indicates the characteristic of DC output when charging a battery. The voltage may be decreased by 20% when the resistance load is applied.

*NOTE : It is possible to use both DC and AC outputs simultaneously up to the rated output in total.*

## **3. FEATURES**

### **3-1 BRUSHLESS ALTERNATOR**

Newly developed brushless alternator eliminates troublesome brush maintenance.

### **3-2 CONDENSER TYPE VOLTAGE REGULATOR**

A trouble free condenser type voltage regulator ensures a stable voltage under all working conditions.

### **3-3 OIL SENSOR**

Oil sensor automatically shuts off the engine whenever the oil level falls down below the lower limit to protect the engine from seizure.

### **3-4 QUIET OPERATION**

Robin RGV series generator delivers a quiet operation with :

- \* A large super silent muffler.
- \* A quiet 4-stroke Robin Rro OHV engine.
- \* A silent cyclone air cleaner.

### **3-5 NO RADIO NOISE**

Noise suppressor spark plug is equipped standard to prevent radio frequency interference.

### **3-6 LARGE FUEL TANK**

The large fuel tank allows more than 7 to 10 hours of continuous operation which is sufficient for a half day or one day work without refueling.

### **3-7 RUGGED TUBULAR FRAME**

Full cradle type rugged tubular frame protects the generator all around.

### **3-8 COMPACT AND LIGHT WEIGHT**

Newly developed brushless alternator enabled the RGV generators to be very compact in size and light in weight.



### **3-9 MINIMAL MAINTENANCE**

- \* A brushless alternator release the operator from periodical brush maintenance.
- \* A trouble free condenser type voltage regulator.
- \* A drip-proof alternator design.
- \* No-fuse circuit breakers.
- \* An electronic pointless ignition system.
- \* A dust-proof cyclone air cleaner.

### **3-10 LONG-LIFE DURABILITY**

The heavy-duty 4 stroke Robin Rro OHV engine and virtually maintenance-free brushless alternator ensure greater durability with :

- \* A brushless alternator with a condenser voltage regulator.
- \* Full rubber mount in a sturdy tubular frame.
- \* A forged steel crankshaft supported by two main ball bearings.
- \* A pointless electronic ignition system.
- \* A cast-iron cylinder liner.
- \* A forged aluminum connecting rod.

# 4. GENERAL DESCRIPTION

## 4-1 EXTERNAL VIEW

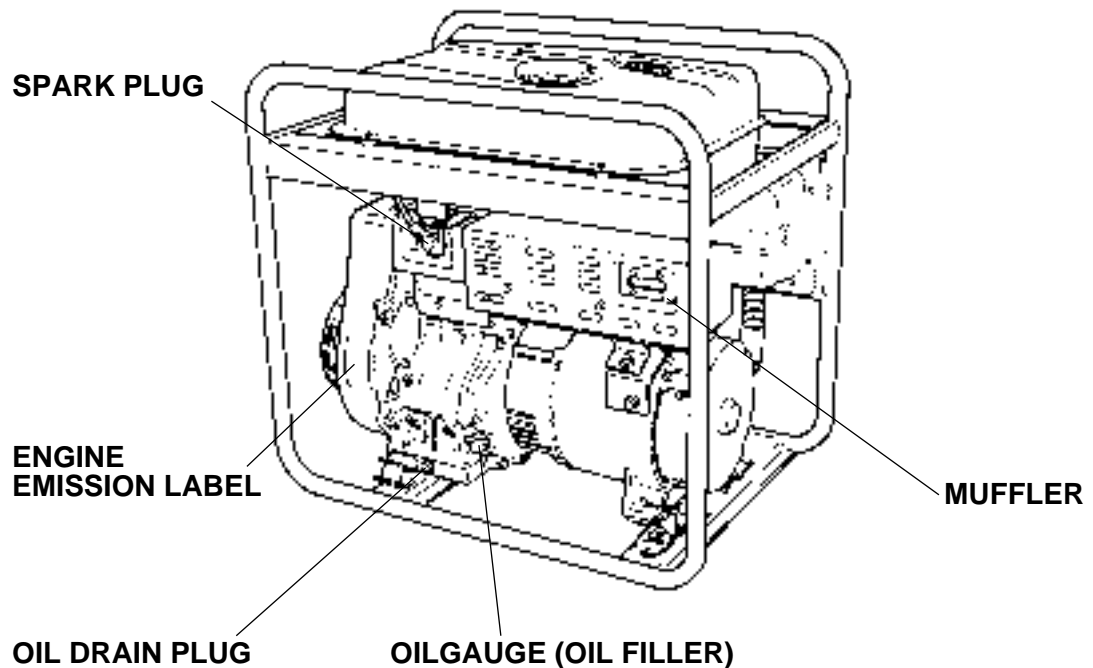
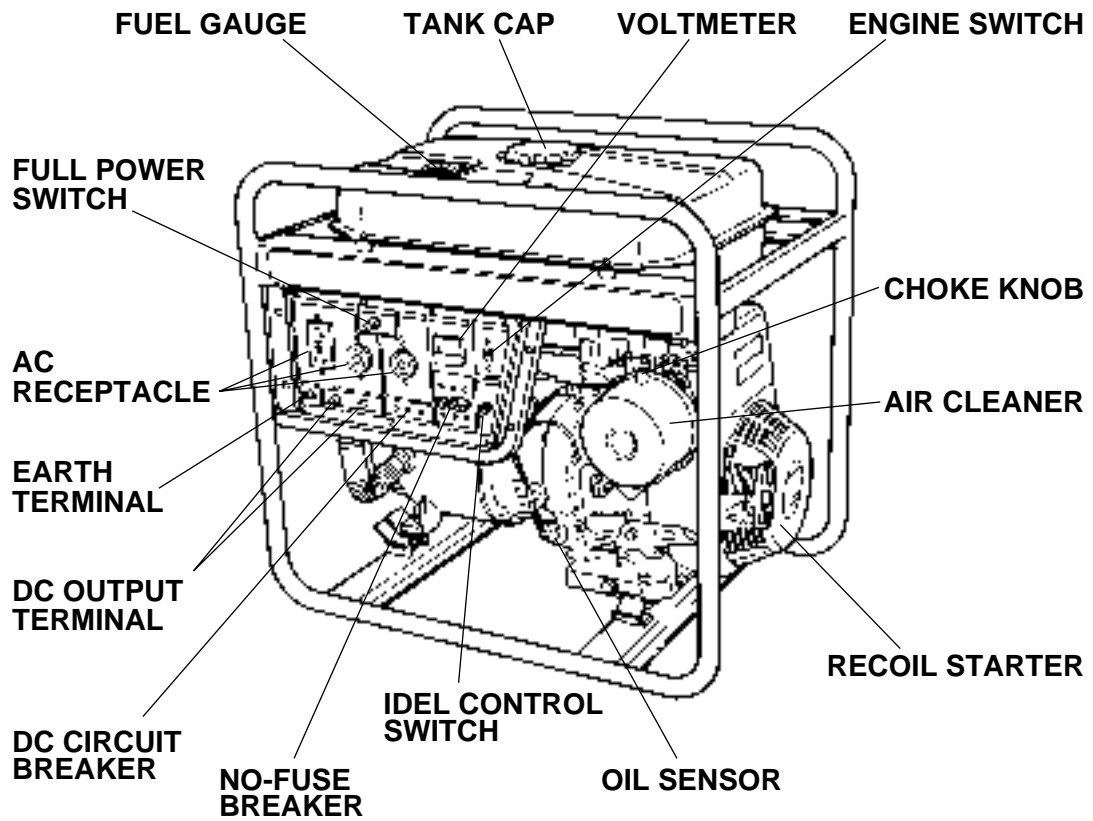

## 4-2 CONTROL PANEL

\* RGV2800 : U.S.A., 60Hz-120V [NEMA RECEPTACLE]

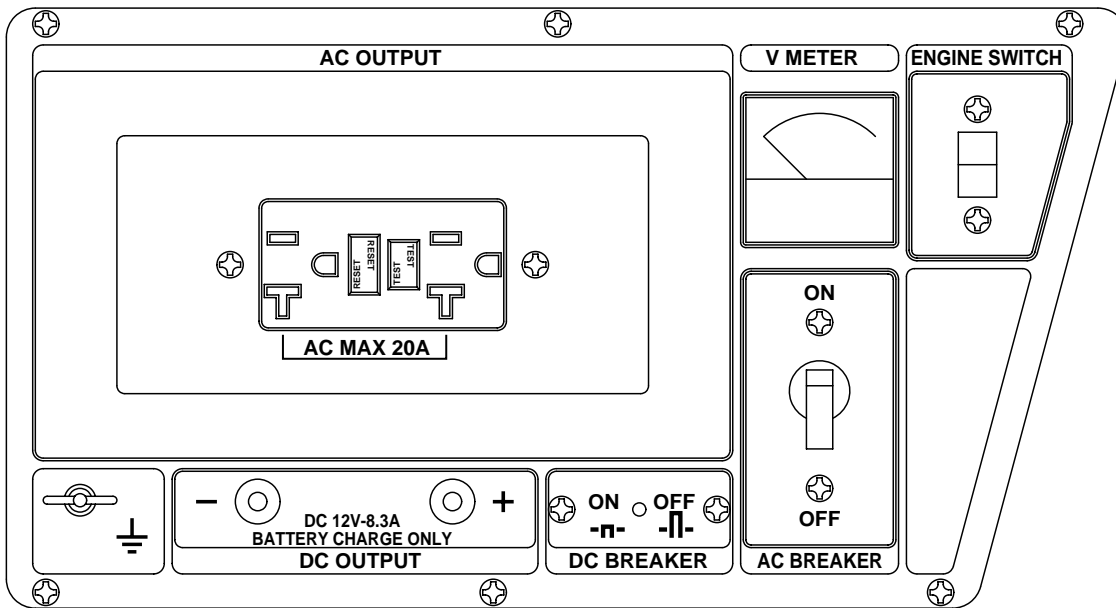

\* RGV4100 : U.S.A., 60Hz-120V/240V [NEMA RECEPTACLE]

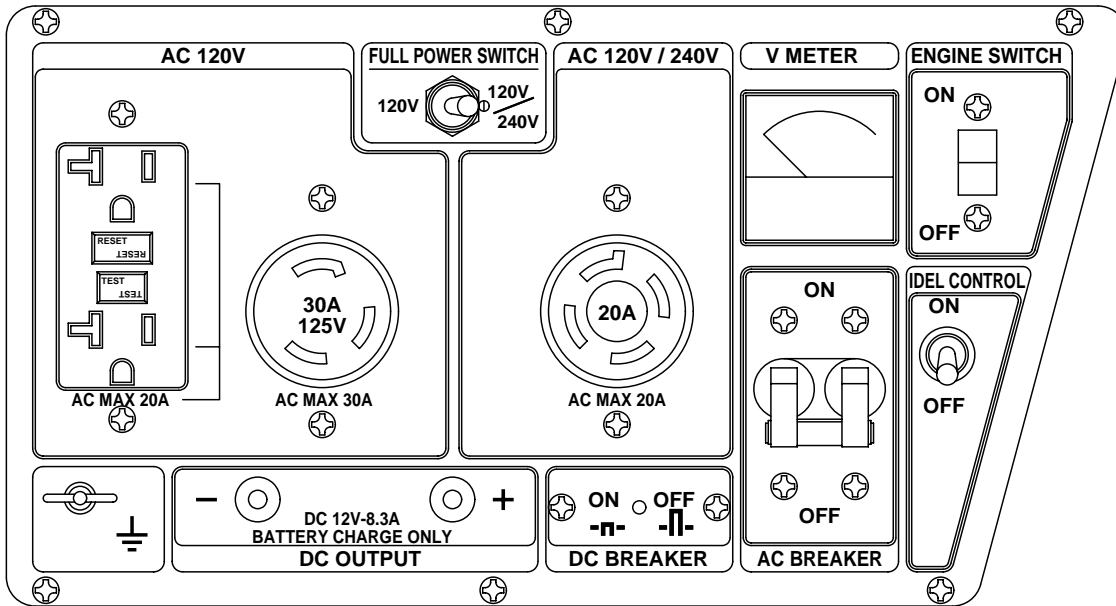

\* RGV6100 : U.S.A., 60Hz-120V/240V [NEMA RECEPTACLE]

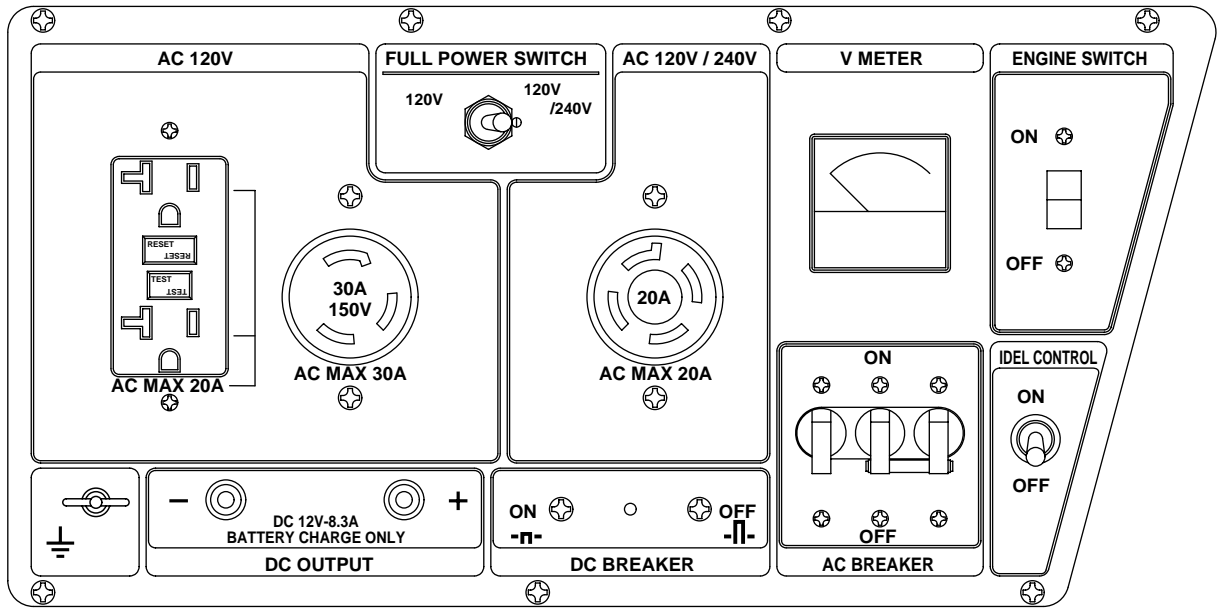

#### 4-3 LOCATION of SERIAL NUMBER and SPECIFICATION NUMBER

Serial number and specification number are stamped on the LABEL (MODEL NAME) stuck on the side wall of control box.

*NOTE : Always specify these numbers when inquiring about the generator or ordering spare parts in order to get correct parts and accurate service.*

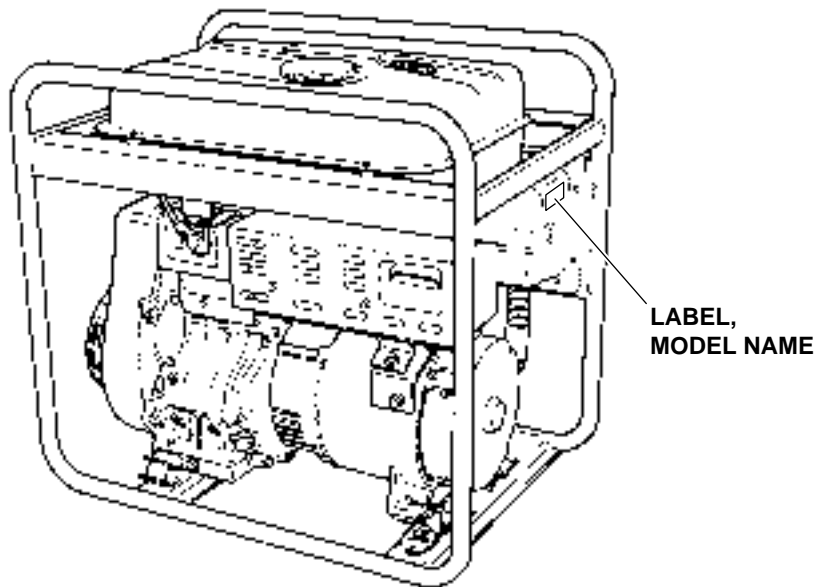

## 5. CONSTRUCTION AND FUNCTION

### 5-1 CONSTRUCTION

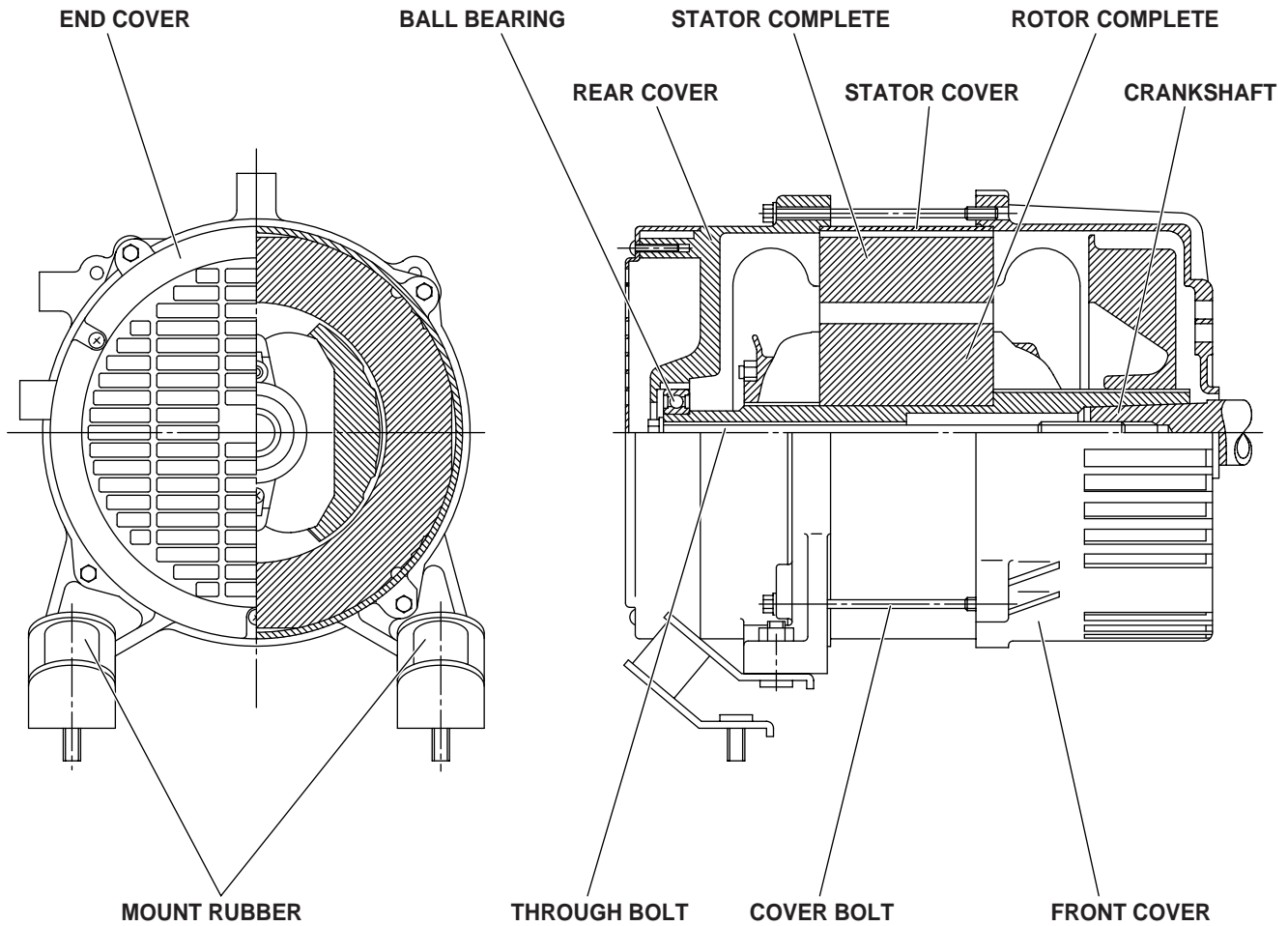

Fig. 5-1

### 5-2 FUNCTION

#### 5-2-1 STATOR

The stator consists of a laminated silicon steel sheet core, a main coil and a condenser coil which are wound in the core slots.

The condenser coil excites the rotor field coil which generates AC voltage in the main coil.

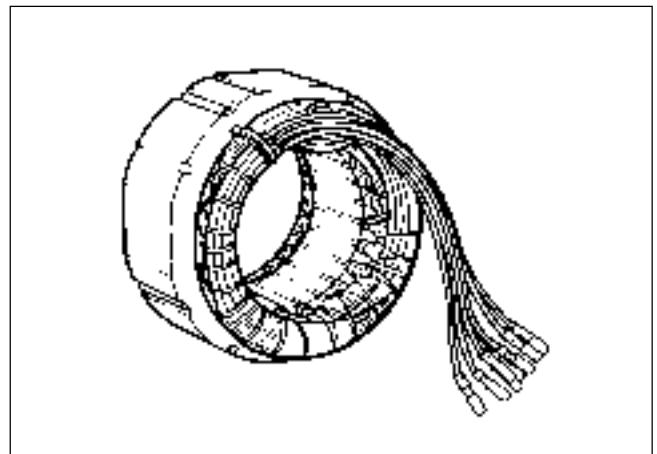

Fig. 5-2

### 5-2-2 CONDENSER

One or two condensers are installed in the control box and are connected to the condenser coil of the stator.

These condensers and condenser coil regulate the output voltage.

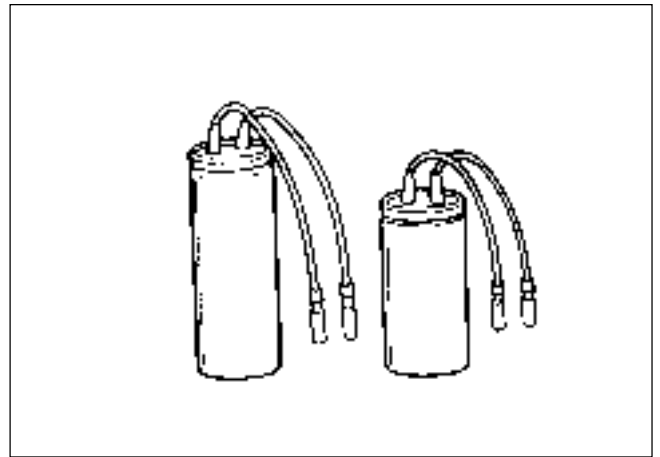

Fig. 5-3

### 5-2-3 ROTOR

The rotor consists of a laminated silicon steel sheet core and a field coil which is wound over the core.

DC current in the field coil magnetizes the steel sheet core. Two permanent magnets are provided for the primary exciting action.

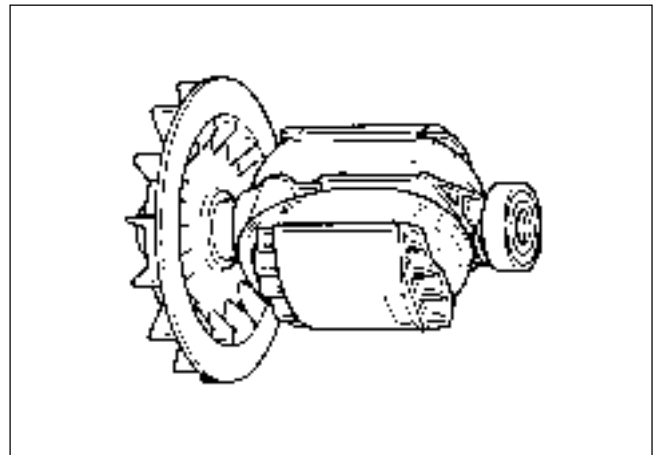

Fig. 5-4

A diode rectifier and surge absorber is mounted inside the insulator.

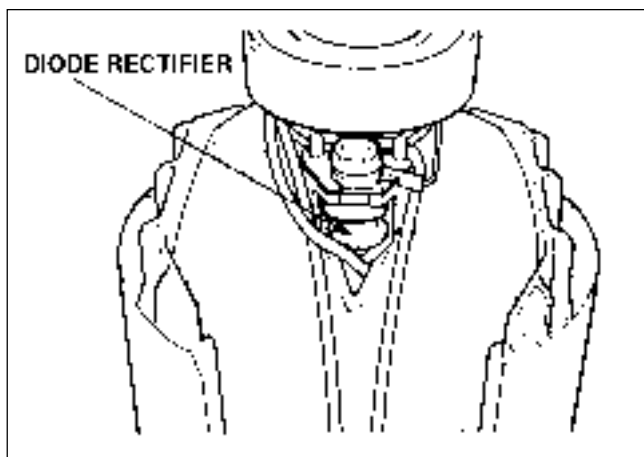

Fig. 5-5A

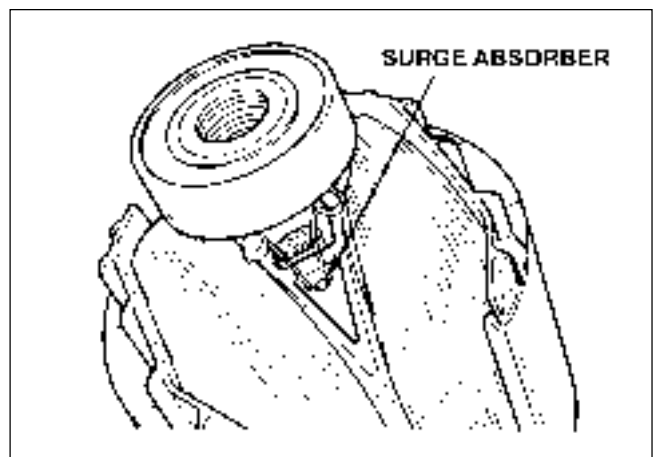

Fig. 5-5B

### 5-2-4 NO-FUSE BREAKER

The no-fuse breaker protects the generator from getting damage by overloading or short circuit in the appliance. Table 5-1 shows the capacity of no-fuse breaker by each spec. and their object of protection.

MODEL	SPECIFICATION	NO-FUSE BREAKER	OBJECT or PROTECTION
RGV2800	60 Hz-120V	20 A	Total output amperage
RGV4100	60 Hz-120 V/ 240V	15 A (2-Pole, 2-Element)	Total output amperage
RGV6100	60 Hz-120 V/ 240V	20 A (2-Pole, 2-Element)	Total output amperage
		30 A	Output from 30A receptacle

Table. 5-1

### 5-2-5 DC CIRCUIT BREAKER

The 10 ampere DC circuit breaker mounted on the control panel protects whole DC circuit from getting damage by overload or short circuit.

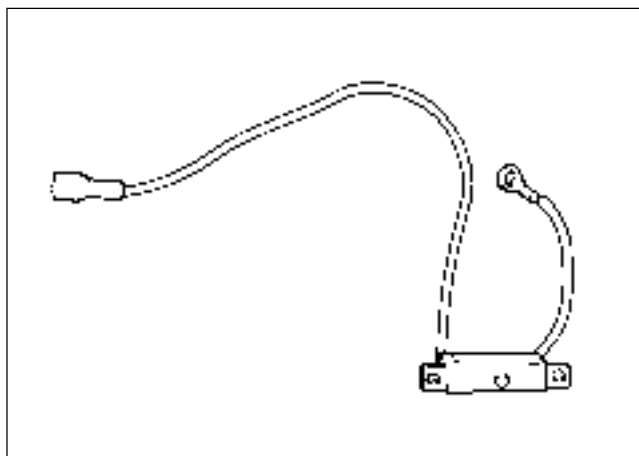

Fig. 5-6

### 5-2-6 RECEPTACLE and AC PLUG (STD. SPEC.)

These are used for taking AC output power from the generator. A total of six kinds of receptacles, each varying in rated voltage and current from another, are used. Each model has at least one receptacle to deliver the rated generator output. As many AC plugs as the receptacles, each matching the corresponding receptacle, are provided. Table 5-2 shows the rated current for each receptacle. Be careful not to use the receptacles and AC plugs beyond the specified amperage limits to prevent burning.



Style	Ampere	Receptacle	AC plug	Description
	up to 20A	NEMA 5-20A	NEMA 5-20P	GFCI (Ground Fault Circuit Interrupter) Receptacle, duplex (REC1)
	up to 20A	NEMA L14-20R	NEMA L14-20P	Locking Receptacle (REC2)
	up to 30A	NEMA L5-30R	NEMA L5-30P	Locking Receptacle (REC3)

Table. 5-2

*NOTE : If your generator has receptacles peculiar to your country, Table 5-2 does not apply.*

**Caution :**

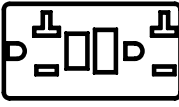
The duplex 120V receptacle is protected by a GFCI (Ground Fault Circuit Interrupter). GFCI shuts off the output current from the duplex 120V receptacle when a ground fault occurs in the generator or the appliance. Please note that other receptacles are not protected by GFCI.

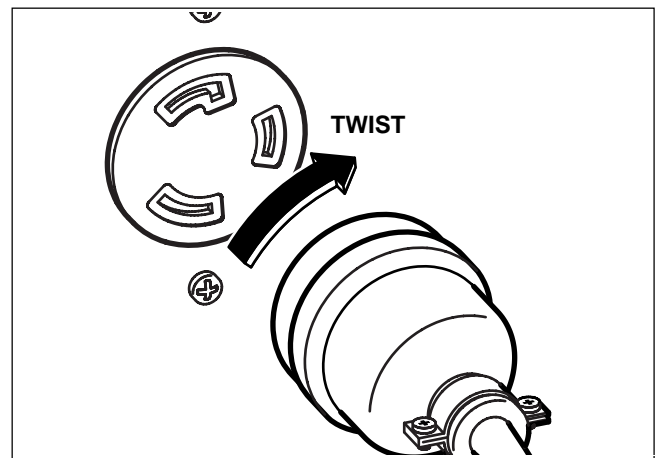

**Caution :** To connect the appliance to locking receptacle, insert the plug into the receptacle and turn it clockwise to lock.

Fig. 5-8

### 5-2-7 GFCI RECEPTACLE

After starting the engine, check the GFCI for proper functioning by the following test procedure.

Push yellow TEST button, The red RESET button will pop out exposing the word TRIP. Power is now off at the outlets protected by the GFCI, indicating that the device is functioning properly.

If TRIP dose not appear when testing, do not use the generator. Call a qualified electrician.

To restore power, push RESET button.

**WARNING :**

If the RESET button pops out during operation, stop the generator immediately and call a qualified electrician for checking generator and the appliances.



## 5-2-8 CONNECTING TO DOMESTIC CIRCUITS (HOUSE WIRING)

### WARNING :

All Robin generators are a neutral ungrounded type.

If a generator is to be connected to residential or commercial power lines, such as a stand-by power source during power outage, all connections must be made by a licensed electrician.

Failure in connection may result in death, personal injury, damage to generator, damage to appliances, damage to the building's wiring or fire.

(a) When connecting a Robin generator to a house wiring, generator output power must be taken from the 240V-4P receptacle.

(b) Install a transfer switch.

A transfer switch must be installed to transfer the load from the commercial power source to the generator. This switch is necessary to prevent accidents caused by the recovery from power outage. Use a transfer switch of the correct capacity. Install transfer switch between the meter and the fuse or AC breaker box.

Caution : If the neutral wire of house wiring is grounded, be sure to ground the ground terminal of the generator. Otherwise an electric shock may occur to the operator.

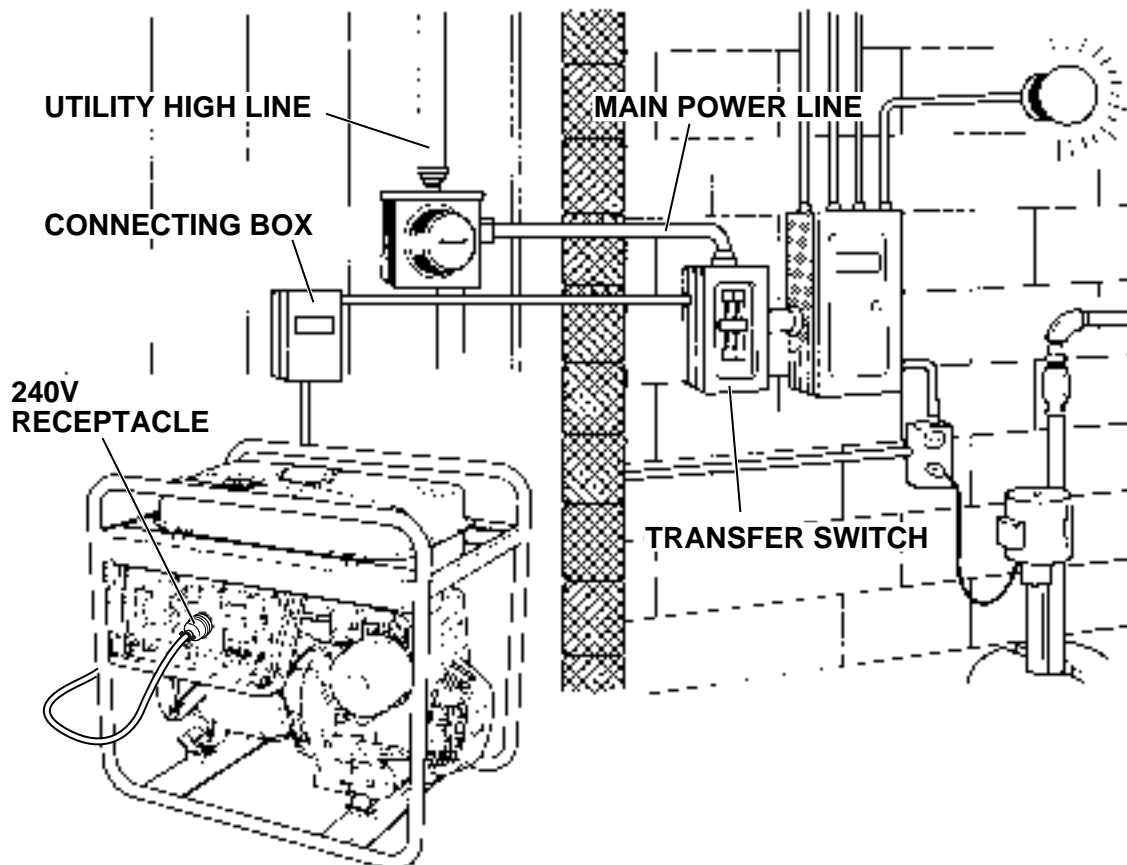

Fig. 5-9

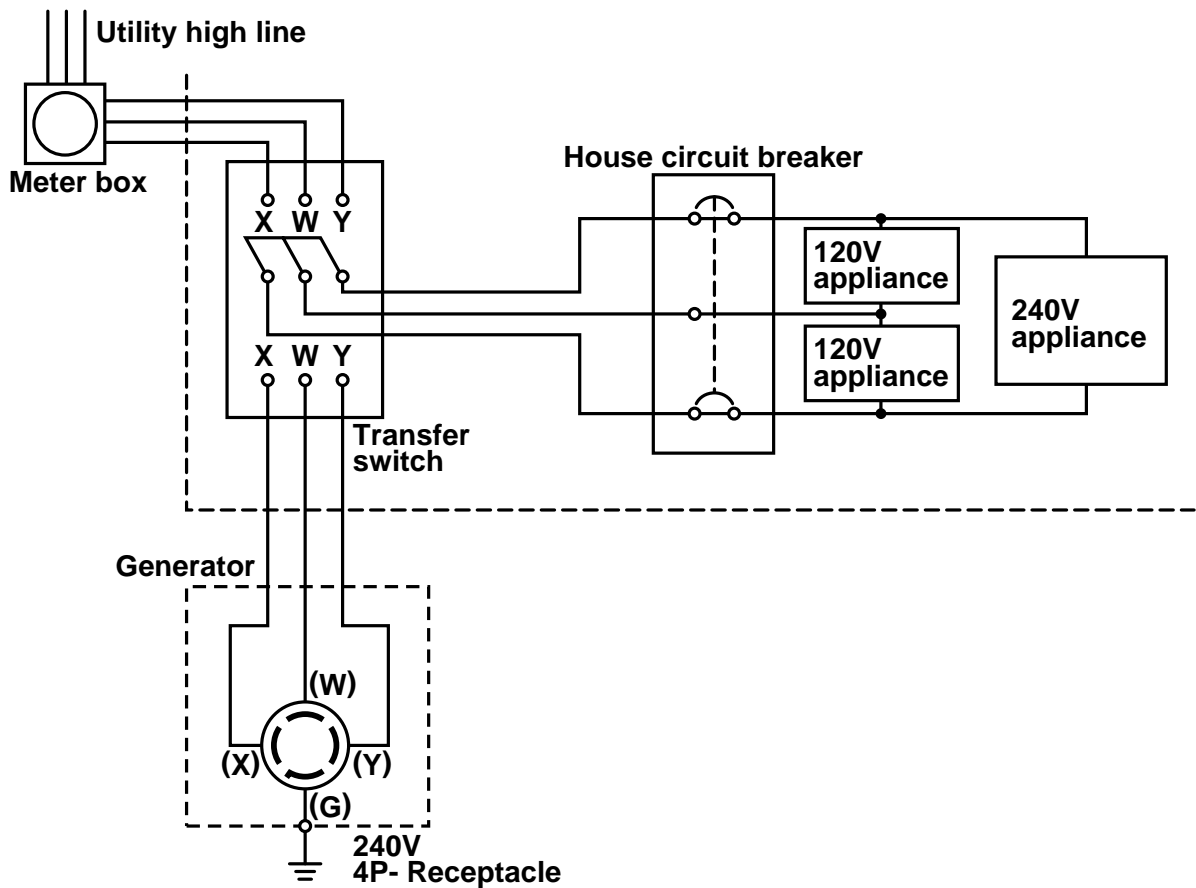

Fig. 5-10

(c) Operating the generator.

Set the full power switch to 120V/ 240V side.

Turn the house AC breaker off before starting the generator.

Start the generator and warm it up.

Turn the house AC breaker on.

Caution : Do not start the generator with electrical appliance (s) connected and with their switches on. Otherwise the appliance (s) may be damaged by the surge voltage at starting.

## 5-3 GENERATOR OPERATION

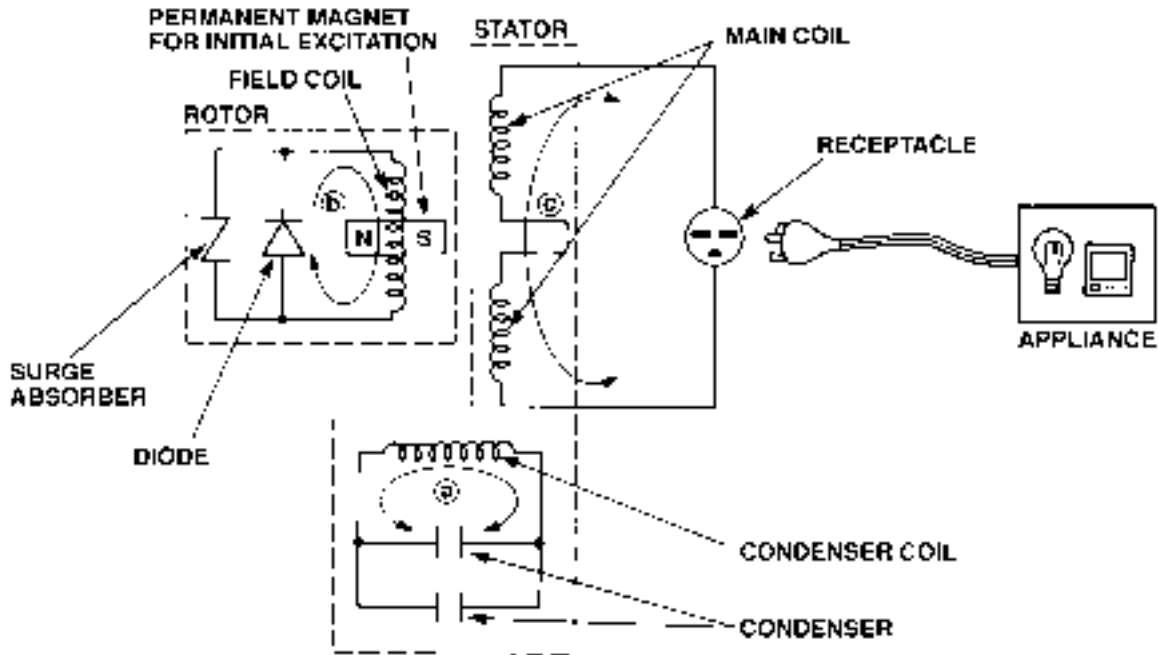

Fig. 5-11

### 5-3-1 GENERATION of NO-LOAD VOLTAGE

- (1) When the generator starts running, the permanent magnet built-in to the rotor generates 3 to 6V of AC voltage in the main coil and condenser coil wound on the stator.
- (2) As one or two condensers are connected to the condenser coil, the small voltage at the condenser coil generates a minute current (a) which flows through the condenser coil. At this time, a small flux is produced with which the magnetic force at the rotor's magnetic pole is intensified. When this magnetic force is intensified, the respective voltages in the main coil and condenser coil rise up. As the current (a) increases, the magnetic flux at the rotor's magnetic pole increases further. Thus the voltages at the main coil and condenser coil keep rising by repeating this process.
- (3) As AC current flows through the condenser coil, the density of magnetic flux in the rotor changes. This change of magnetic flux induces AC voltage in the field coil, and the diode rectifier in the field coil circuit rectifies this AC voltage into DC. Thus a DC current (b) flows through the field coil and magnetizes the rotor core to generate an output voltage in the main coil.
- (4) When generator speed reaches 3000 to 3300 rpm, the current in the condenser coil and field coil increases rapidly. This acts to stabilize the output voltage of each coils. If generator speed further increases to the rated value, the generator output voltage will reach to the rated value.

### 5-3-2 VOLTAGE FLUCTUATIONS UNDER LOAD

When the output current (c) flows through the main coil to the appliance, a magnetic flux is produced and serves to increase current (a) in the condenser coil. When current (a) increases, the density of magnetic flux across the rotor core rises. As a result, the current flowing in the field coil increases and the generator output voltage is prevented from decreasing.

### 5-3-3 FULL POWER SWITCH (Dual Voltage Type)

The full power switch is provided for the dual voltage type to take out the full rated power from one receptacle in each voltage.

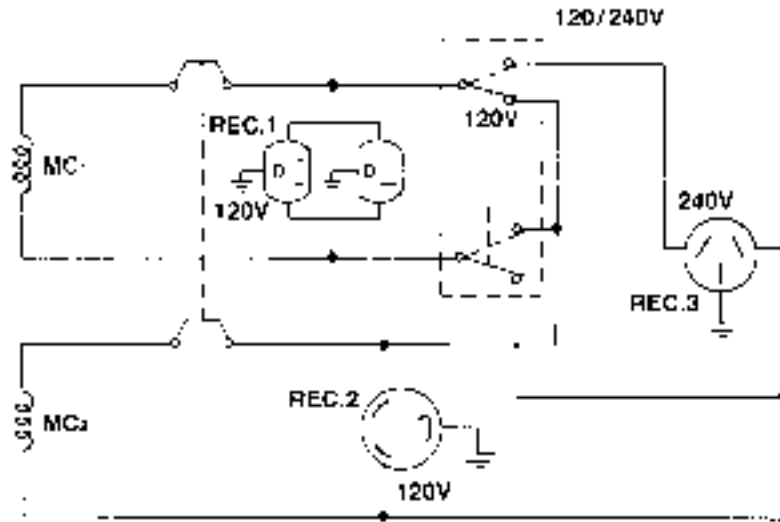

Fig. 5-12

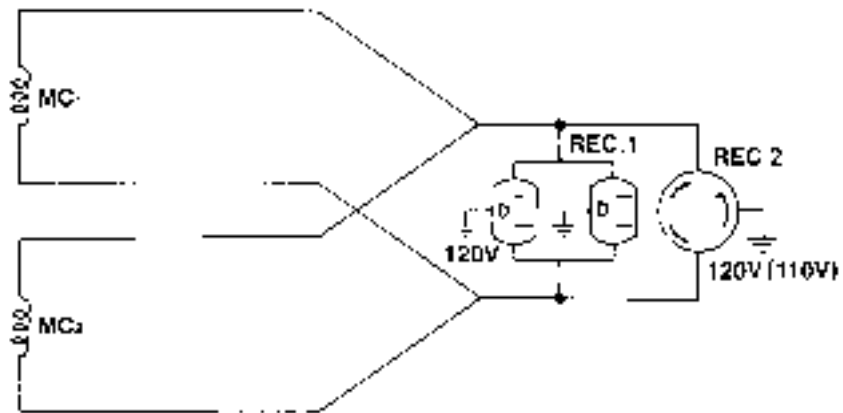

Fig. 5-13

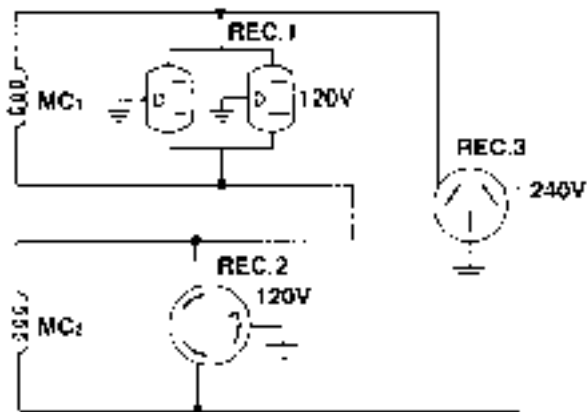

Fig. 5-14

Switch Position	LOWER VOLTAGE RECEPTACLE	HIGHER VOLTAGE RECEPTACLE
120/240 V	Half of rated output	Rated output

Table 5-3

Two main coils are wound over stator core. Each main coil outputs half the rated power at the lower voltage (120V). These main coils are wound to be in the same phase. The full power switch reconnects these main coils in parallel or in series.

Fig. 5-12 shows a circuit diagram. When the full power switch is set for single lower voltage indication (120V), the switch position is as indicated by the lower solid line in the diagram. Fig. 5-13 is a simplified representation of this circuit, showing the two main coils connected in parallel. In this case, the higher voltage (240V) at Rec. 3 cannot be taken out. Rec. 2 for the lower voltage can output up to the rated power (up to 30A if the rated current is over 30A), and Rec. 1 can output up to a total of 15A.

When the full power switch is set for double voltage indication (120V/240V), the switch position is as indicated by the upper dotted line in Fig. 5-12. Fig. 5-14 is a simplified representation of this circuit, showing the two main coils connected in series. In this case, power can be taken simultaneously from the receptacles for the both voltages. Rec. 3 for the higher voltage can output up to the rated power, but Rec. 1 and Rec. 2 for the lower voltage can output only up to half the rated power each.

Table 5-4 is a summary of the above explanation. Select the proper output voltage by full power switch in accordance with the appliance to be used.

## 5-4 OIL SENSOR

### 5-4-1 DESCRIPTION

\* The oil sensor mainly functions to detect position of the surface of engine oil in the crankcase of engines for general use and to stop the engine automatically when the oil level goes down below the lower limit specified. This prevents seizure of engine from occurring due to insufficient amount of oil in the crankcase.

\* Since the sensor has been designed to consume a part of power supplied to the igniter to energize its electronics circuit, any other external power supply is not necessary so that it can be mounted at the oil filler port.

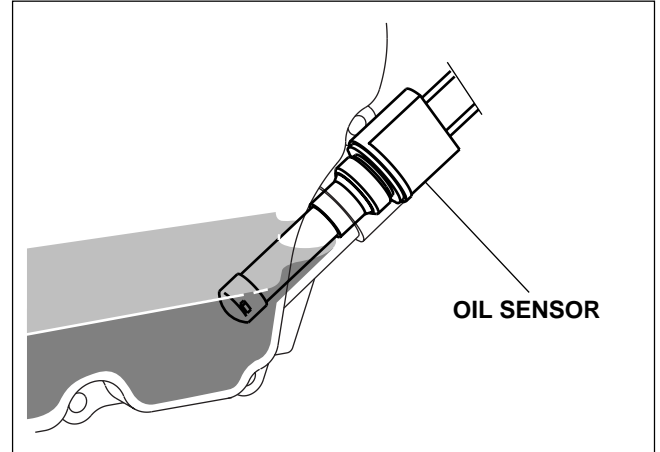

Fig. 5-15

Introduction of newly developed sensing principle features super durability and no change with the passage of time as it does not use any moving part.

Merits due to introduction of electrical conductivity detection are as follows ;

- ① It has resistance to mechanical shocks and property of no change with the passage of time as sensing element consists simply of electrodes having no moving parts.
- ② At the same time, it is capable of detecting the oil level stably as it is not influenced by engine vibrations.
- ③ No error occurs due to foam and flow of the oil.
- ④ Influence against the ignition system or the electronics units can be neglected because an electric current supplied to the sensor can be decreased.

### 5-4-2 PRINCIPLE OF SENSING OIL LEVEL

There is a great difference between electric resistance of air and that of oil. Since the resistance of air is far higher than that of oil, more electric current passes through the oil than through the air, although absolute value of the current is very small. The sensor detects this current difference and make use of it. The sensor judges the oil quantity, by comparing a current flowing across a pair of electrodes (inner and outer) with the reference, in such a way that if a current flows between the electrodes more than the reference, sufficient oil is in the crankcase, on the other hand, if a current flows less than the reference, oil is not sufficient. Since an electric current is flown to detect oil quantity, this is called the “electrical conductivity detection” type of sensor. The oil level to be detected is determined by the length of electrodes and their mounting positions with the engine.

### 5-4-3 HOW IT OPERATES

#### [Power supply]

The sensor makes use of a part of primary power source for ignition of the engine (igniter) to drive the sensor circuit. Power to the sensor can usually be derived from the “stop button” by branching wires out.

### [Judgement of oil level]

When sufficient oil is in the crankcase, both of inner and outer electrodes are immersed in the oil through which current flows across the electrodes. The sensor judges that oil in the crankcase is sufficient. When oil level goes down and the inner electrode is exposed to the air due to consumption of oil, no current flow between the electrodes as air is considered to be electrically nonconductive. The sensor in this case judges that oil is insufficient.

### [Decision of oil shortage]

Oil level at the electrodes may go down momentarily probably due to the engine being slanted or affected by vibration even if a sufficient oil is in the crankcase. For that reason, the sensor has an electronic timer circuit to prevent it from interpreting as short of oil when amount of oil is sufficient. The sensor has been designed so that the engine is to be stopped only when oil-shortage is detected for 5 seconds uninterrupted. The timer employs an integration circuit and it is to be reset when the inner electrode is soaked in the oil again before the sensor decides it as oil-shortage. The oil level where the sensor decides as oil-shortage, when oil level goes down gradually, is called “threshold level”.

### [Automatic stop of engine]

When the sensor decides as oil-shortage, it makes the engine to stop running automatically for protection of engine. Once the stopping circuit is activated, it keeps functioning until it confirms that the engine has made a complete stop, then the circuit stops functioning automatically.

### 5-4-4 BLOCK DIAGRAM OF THE CIRCUIT

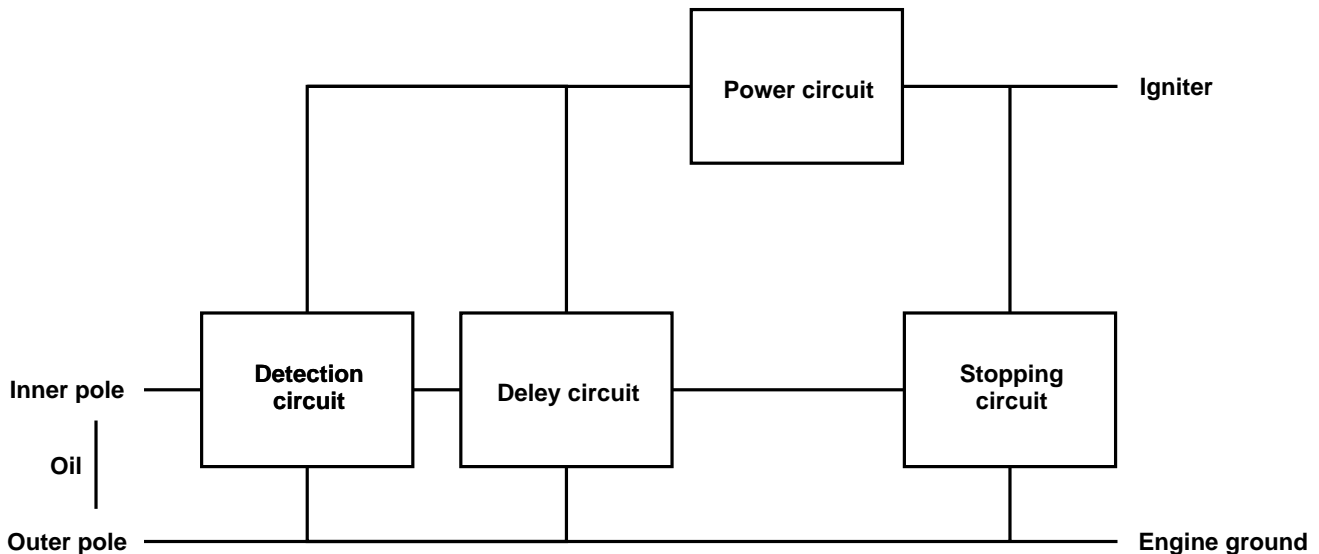

Fig. 5-16

- ① Power circuit ..... This rectifies a part of power to the igniter and regulates it to supply the stabilized power to necessary circuits.

- ② Detection circuit ..... This detects quantity of oil, sufficient or not, according to difference of electric resistance across inner and outer electrodes.
- ③ Delay circuit ..... This prevents the sensor from making an unnecessary stop of the engine by momentary lowering of the oil level due to the engine being slanted or affected by vibration in spite of sufficient oil in the crankcase.
- ④ Stopping circuit ..... This automatically stops the engine running.

#### **5-4-5 CAUTIONS TO BE TAKEN ON HANDLING THE SENSOR**

##### **(1) Oil sensor unit**

- ① Be sure not to damage each wire. Broken or short-circuited power supply wires and/or a grounding wire in particular may lead to malfunction or breakdown.
- ② The sensor is not interchangeable from engine to engine because the sensor is to be exclusively installed individually in each engine employed.

##### **(2) Mounting and wiring of oil sensor unit**

- ① Although this has been designed to have enough antinoise properties in practical use, do not route the sensor wirings in the vicinity of noise-generating sources such as ignition plugs or high voltage cords. This may cause malfunction or breakdown.
- ② Since capacity of power source is limited, current flow in the electronic circuit of the sensor is kept as low as possible. Be sure to use terminals with a high contact reliability of more than that of tinned terminals.

##### **(3) Operation of oil sensor**

- ① If operating with the engine kept tilted, oil surface inside of the engine varies and the correct oil level can not be detected which in turn obstructs the preventing function of engine seizure. Operate the engine by keeping it level.
- ② When starting the engine with an insufficient oil in the crankcase, engine starts once then it stops automatically after it runs for 5 seconds.
- ③ When the engine has been stopped by the oil sensor, voltage remained in the electronic circuit prevents the sensor from being restarted for 3 seconds after the engine stop. Try to restart the engine after 3 seconds or more.



## 6. SAFETY PRECAUTIONS

### 1. Use extreme caution near fuel. A constant danger of explosion or fire exists.

Do not fill the fuel tank while the engine is running. Do not smoke or use open flame near the fuel tank. Be careful not to spill fuel when refueling. If spilt, wipe it and let dry before starting the engine.

### 2. Do not place inflammable materials near the generator.

Be careful not to put fuel, matches, gunpowder, oily cloth, straw, and any other inflammables near the generator.

### 3. Do not operate the generator in a room, cave or tunnel. Always operate in a well-ventilated area.

Otherwise the engine may overheat and also, the poisonous carbon monoxide contained in the exhaust gases will endanger human lives. Keep the generator at least 1 m (4 feet) away from structures or facilities during use.

### 4. Operate the generator on a level surface.

If the generator is tilted or moved during use, there is a danger of fuel spillage and a chance that the generator may tip over.

### 5. Do not operate with wet hands or in the rain.

Severe electric shock may occur. If the generator is wet by rain or snow, wipe it and thoroughly dry it before starting. Don't pour water over the generator directly nor wash it with water. If the generator is wet with water, the insulations will be adversely affected and may cause current leakage and electric shock.

### 6. Do not connect the generator to the commercial power lines.

This may cause a short-circuit or damage to the generator. Use a transfer switch (Optional parts) for connecting with indoor wiring.

*NOTE : The parts numbers of the transfer switches and of the plastic box to store them are as shown in Table 6-1.*

Part No.	Part Name	Q'ty	Phase	Allowable Current
365-45604-08	Transfer Switch	1	1	15 A
367-45605-08	Transfer Switch	1	1	30 A
340-45606-08	Transfer Switch	1	1	60 A
367-43008-08	Plastic Box	1	1	30 A
348-43009-08	Plastic Box	1	1	60 A

Table. 6-1

### 7. Be sure to check and remedy the cause of circuit breaker tripping before resetting it on.

**CAUTION :** If the circuit breaker tripped off as a result of using an electrical appliance, the cause can be an overload or a short-circuit. In such a case, stop operation immediately and carefully check the electrical appliance and AC plugs for faulty wiring.

## 7. RANGE OF APPLICATIONS

Generally, the power rating of an electrical appliance indicates the amount of work that can be done by it. The electric power required for operating an electrical appliance is not always equal to the output wattage of the appliance. The electrical appliances generally have a label showing their rated voltage, frequency, and power consumption (input wattage). The power consumption of an electrical appliance is the power necessary for using it. When using a generator for operating an electrical appliance, the power factor and starting wattage must be taken into consideration.

In order to determine the right size generator, it is necessary to add the total wattage of all appliances to be connected to the unit.

Refer to the followings to calculate the power consumption of each appliance or equipment by its type.

### **(1) Incandescent lamp, heater, etc. with a power factor of 1.0**

Total power consumption must be equal to or less than the rated output of the generator.

**Example :** A rated 3000W generator can turn thirty 100W incandescent lamps on.

### **(2) Fluorescent lamps, motor driven tools, light electrical appliances, etc. with a smaller power factor**

Select a generator with a rated output equivalent to 1.2 to 2 times of the power consumption of the load. Generally the starting wattage of motor driven tools and light electrical appliances are 1.2 to 3 times larger than their running wattage.

**Example :** A rated 250 W electric drill requires a 400 W generator to start it.

*NOTE1 : If a power factor correction capacitor is not applied to the fluorescent lamp, the more power shall be required to drive the lamps.*

*NOTE2 : Nominal wattage of the fluorescent lamp generally indicates the output wattage of the lamp. Therefore, if the fluorescent lamp has no special indication as to the power consumption, efficiency should be taken into account as explained in Item (5) on the following page.*

### **(3) Mercury lamps with a smaller power factor**

Loads for mercury lamps require 2 to 3 times the indicated wattage during start-up.

**Example :** A 400 W mercury lamp requires 800 W to 1200 W power source to be turned on. A rated 3000 W generator can power two or three 400 W mercury lamps.

### **(4) Initially loaded motor driven appliances such as water pumps, compressors, etc.**

These appliances require large starting wattage which is 3 to 5 times of running wattage.

**Example :** A rated 900 W compressor requires a 4500 W generator to drive it.

*NOTE1 : Motor-driven appliances require the aforementioned generator output only at the starting. Once their motors are started, the appliances consume about 1.2 to 2 times their rated power consumption so that the excess power generated by the generator can be used for other electrical appliances.*

*NOTE2 : Motor-driven appliances mentioned in items (3) and (4) vary in their required motor starting power depending on the kind of motor and start-up load. If it is difficult to determine the optimum generator capacity, select a generator with a larger capacity.*

**(5) Appliances without any indication as to power consumption**

Some appliances have no indication as to power consumption; but instead the work load (output) is indicated. In such a case, power consumption is to be worked out according to the numerical formula mentioned below.

$$\frac{\text{(Output of electrical appliance)}}{\text{(Efficiency)}} = \text{(Power consumption)}$$

Efficiencies of some electrical appliances are as follows :

- Single-phase motor ..... 0.6 to 0.75
  - Fluorescent lamp ..... 0.7 to 0.8
- ( The smaller the motor, the lower the efficiency. )

**Example 1:** A 40W fluorescent lamp means that its luminous output is 40W. Its efficiency is 0.7 and accordingly, power consumption will be  $40 \div 0.7 = 57W$ . As explained in Item (2), multiply this power consumption value of 57 W by 1.2 to 2 and you will get the figure of the necessary capacity of a generator. In other words, a generator with a rated output of 1000W capacity can light nine to fourteen 40 W fluorescent lamps.

**Example 2 :** Generally speaking, a 400 W motor means that its work load is 400 W. Efficiency of this motor is 0.7 and power consumption will be  $400 \div 0.7 = 570 W$ . When this motor is used for a motor-driven tool, the capacity of the generator should be multiple of 570 W by 1.2 to 3 as explained in the Item (3).  $570 (W) \times 1.2 \text{ to } 3 = 684 (W) \text{ to } 1710 (W)$

MODEL	RGV2800	RGV4100	RGV6100
Frequency	60 H		
Incandesent lamp, heater, etc.	2300 W	3600 W	4800 W
Fluorescent lamp, Motor-driven tool, general-porpose	approx. 1200 W	approx. 1800 W	approx. 2400 W
Mercury lamp, etc.	approx. 800 W	approx. 1400 W	approx. 1600 W
Pump, compressor, etc.	approx. 550 W	approx. 850 W	approx. 1100 W

Table. 7-1

**NOTES : Wiring between generator and electrical appliances**

**1. Allowable current of cable**

Use a cable with an allowable current that is higher than the rated input current of the load (electrical appliance). If the input current is higher than the allowable current of the cable used, the cable will become excessively heated and deteriorate the insulation, possibly burning it out. Table 7-2 shows cables and their allowable currents for your reference.

**2. Cable length**

If a long cable is used, a voltage drop occurs due to the increased resistance in the conductors decreasing the input voltage to the load (electrical product). As a result, the load can be damaged. Table 7-2 shows voltage drops per 100 meters of cable.

Sectional area / mm <sup>3</sup>	Allowable current / A	Gauge No./ wire element No./ mm	Resistance Ohm / 100 m	Voltage drop per 100 m						
				1 A	3 A	5 A	8 A	10 A	12 A	15 A
0.75	7	30 / 0.18	2.477	2.5 V	8 V	12.5 V				
1.25	12	50 / 0.18	1.486	1.5 V	5 V	7.5 V	12 V	15 V	18 V	
2.0	17	37 / 0.26	0.952	1.0 V	3 V	5.0 V	8 V	10 V	12 V	15 V
3.5	23	45 / 0.32	0.517		1.5 V	2.5 V	4 V	5 V	6.5 V	7.5 V
5.5	35	70 / 0.32	0.332		1 V	2 V	2.5 V	3.5 V	4 V	5 V

Table. 7-2

Voltage drop indicates as  $V = \frac{1}{100} \times R \times I \times L$

R means resistance ( / 100 m) on the above table.

I means electric current through the wire (A).

L means the length of the wire (m).

The length of wire indicates round length, it means twice the length from generator to electrical tools.

## 8. MEASURING PROCEDURES

### 8-1 MEASURING INSTRUMENTS

#### 8-1-1 “Dr. ROBIN” GENERATOR TESTER

The “Dr. Robin” generator tester is exclusively designed for fast, easy diagnosis and repair of Robin generators. The “Dr. Robin” has the following features :

- (1) Functions of voltmeter, frequency meter, megger tester, capacitance meter and circuit tester are combined in one unit.
- (2) Fast and easy readout by digital indicator.
- (3) Built-in automatic battery checker indicates the time to change batteries.
- (4) Tester and accessories are installed in a handy, sturdy case for easy carrying.

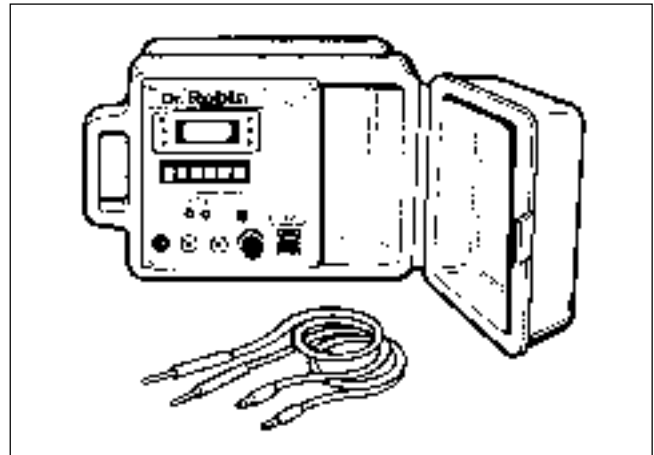

Fig. 8-1

#### \* SPECIFICATIONS

MODEL		Dr. Robin
Part Number		388-47565-08
Measuring Range	Voltage	0 to 500 V AC
	Frequency	25 to 70 Hz
	Resistance	0.1 to 1.999
	Condenser Capacity	10 to 100 $\mu$ F
	Insulation Resistance	3M
Circuit Protector		Fuse
Power Source		2 x 6F44P (006P) Dry Cell Battery
Accessories		Test leads with needle probes . . . 1 set Test leads with jack plugs . . . 1 set
Dimensions (L x W x H)		285 mm x 200 mm x 110 mm
Weight		1.6 kg

Table. 8-1

The “Dr. Robin” generator tester can be ordered from Robin generator distributors by the following part number.

**Dr. Robin Part Number : 388-47565-08**

If you do not have a “Dr. Robin” generator tester, use the instruments described in the following section for checking generator parts.

## 8-1-2 INSTRUMENTS

### (1) VOLTMETER

AC voltmeter is necessary. The approximate AC voltage ranges of the voltmeters to be used for various types of generators are as follows:

0 to 150V : Type with an output voltage of 110 or 120V

0 to 300V : Type with an output voltage of 220, 230 or 240V

0 to 150V, 0 to 330V : Dual voltage type

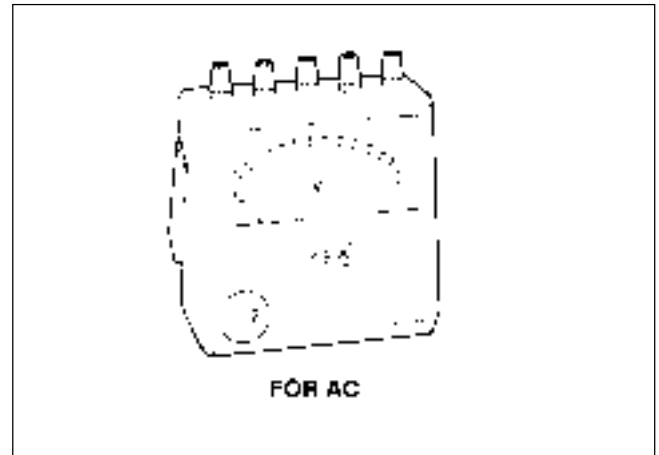

Fig. 8-2

### (2) AMMETER

AC ammeter is necessary. An AC ammeter with a range that can be changed according to the current rating of a given generator is most desirable. (About 10A, 20A, 100A)

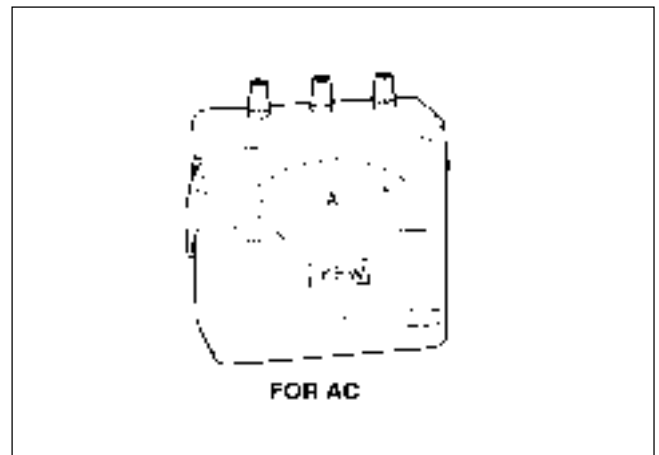

Fig. 8-3

### (3) FREQUENCY METER

Frequency range : About 45 to 65Hz

*NOTE : Be careful of the frequency meter's input voltage range.*

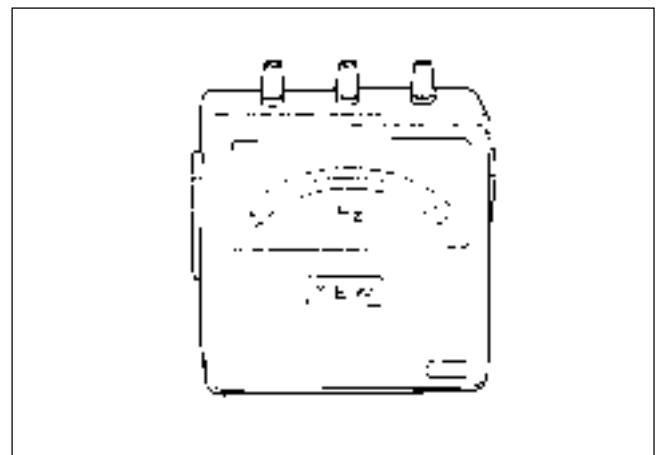

Fig. 8-4

(4) CIRCUIT TESTER

Used for measuring resistance, etc.

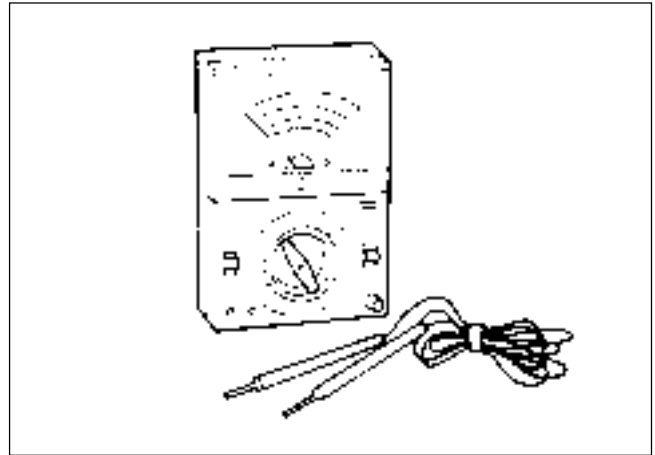

Fig. 8-5

(5) MEGGER TESTER

Used for measuring generator insulation resistance. Select one with testing voltage range of 500V.



Fig. 8-6

(6) TACHOMETER

Use the contactless type tacho meter.

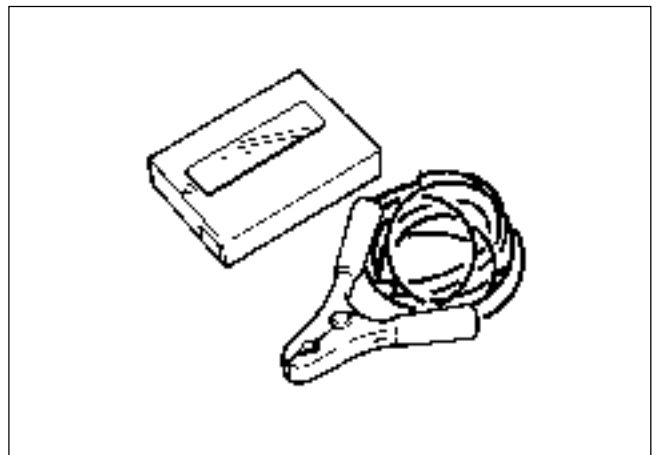

Fig. 8-7

## 8-2 AC OUTPUT MEASURING

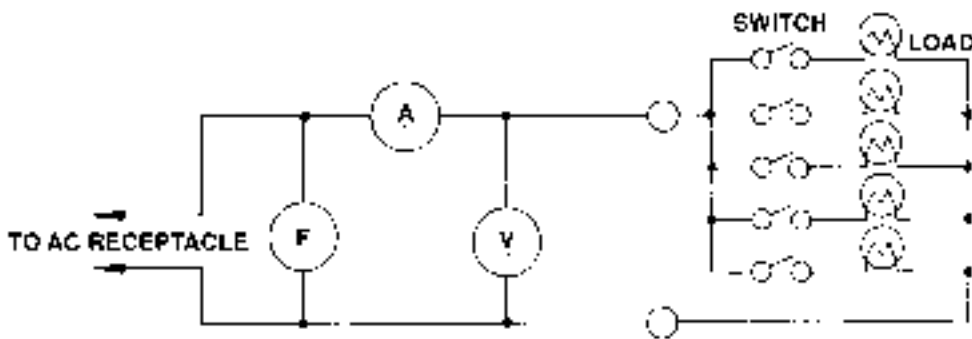

Fig. 8-8

Use a circuit like the shown in Fig.8-8 for measuring AC output. A hot plate or lamp with a power factor of 1.0 may be used as a load. Adjust the load and rpm. and check that the voltage range is as specified in Table 8-2 at the rated amperage and rated rpm.

Rated voltage	120 V	240 V
Voltage range	108 -132 V	216 - 264 V

Table. 8-2

## 8-3 DC OUTPUT MEASURING

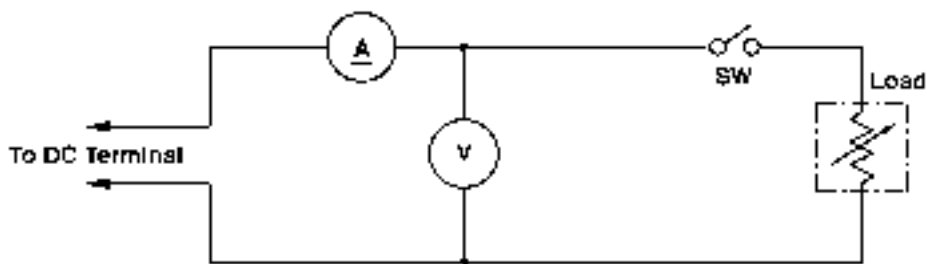

Fig. 8-9

Measurement of DC output is executed with the switch turned ON while the current is regulated at 8.3A by adjusting the load to the generator. If the voltage is within the range from 6V to 14V, the voltage output is normal.

*NOTE : If a battery is connected as a load to the generator, the DC output voltage will increase by approximately 1 to 2 V. Therefore, carefully observe the electrolyte level and do not overcharge the battery.*



## 8-4 MEASURING INSULATION RESISTANCE

Use a “Dr. Robin” generator tester in megger tester mode or use a megger tester to check the insulation resistance. Connect a megger tester to one of receptacle output terminals and the ground terminal, then measure the insulation resistance. An insulation resistance of 1 megohm or more is normal. (The original insulation resistance at the time of shipment from the factory is 10 megohm or more.) If it is less than 1 megohm, disassemble the generator and measure the insulation resistance of the stator, rotor and control panel individually.

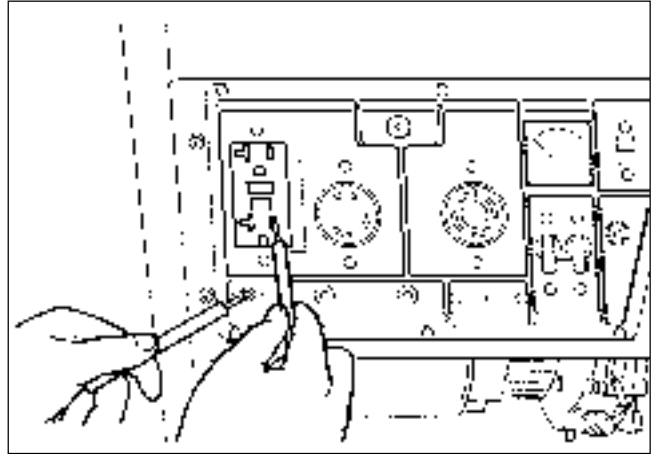

Fig. 8-10

*NOTE : Turn on the no-fuse breaker before measurement.*

### \* STATOR

- (1) Measure the insulation resistance between BLUE lead and the core.
- (2) Measure the insulation resistance between WHITE lead and the core.
- (3) Measure the insulation resistance between YELLOW lead and the core.
- (4) Measure the insulation resistance between BROWN lead and the core.

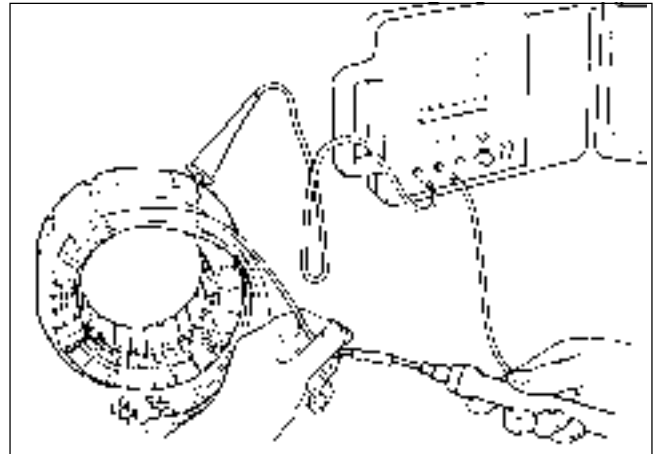

Fig. 8-11

### \* ROTOR

Measure the insulation across one of the soldered terminals of the rotor and the core.

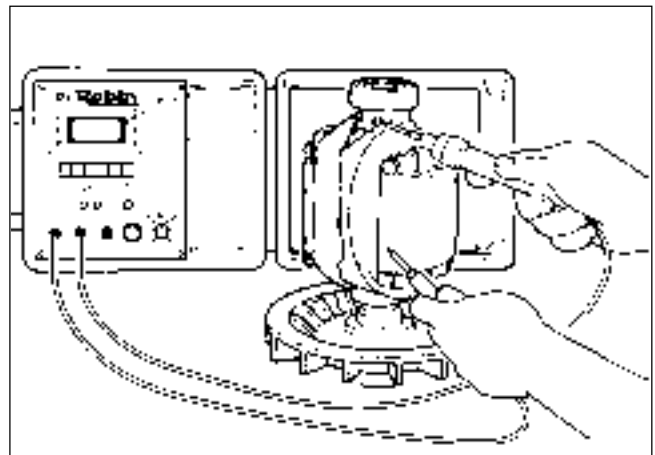
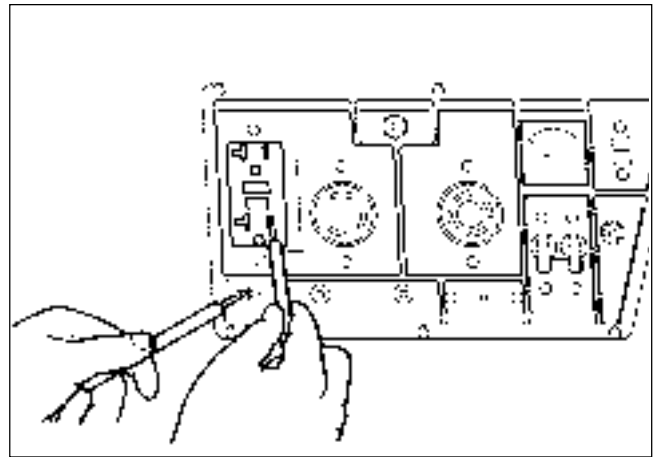

Fig. 8-12

**\* CONTROL PANEL**

Measure the insulation resistances between the live parts and the grounded parts.



*Fig. 8-13*

Any part where the insulation resistance is less than 1M has faulty insulation, and may cause electric leakage and electric shock.

Replace the faulty part.

## 9. CHECKING FUNCTIONAL MEMBERS

### 9-1 VOLTMETER

Check the voltmeter if it is turned on by applying specific voltage. Voltmeter cannot be checked with circuit tester because its resistance is too large.

- ① Check that no disconnection nor short-circuit occurs with a tester, and the internal resistance is around 00k ohms normally.
- ② Turn on the commercial power supply input and check the indication.

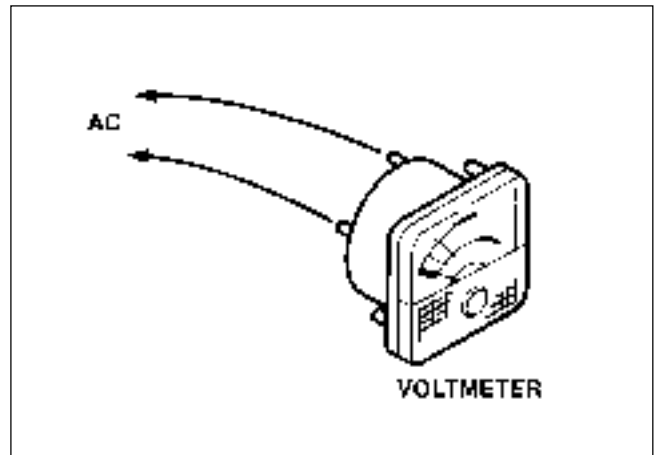

Fig. 9-1

### 9-2 AC RECEPTACLES

Using a "Dr. Robin" or a circuit tester, check continuity between the two terminals at the rear of the AC receptacles while the receptacle is mounted on the control panel. When continuity is found between the output terminals of the receptacle with a wire connected across these terminals, the AC receptacle is normal. When the wire is removed and no continuity is found between these terminals, the receptacles are also normal.

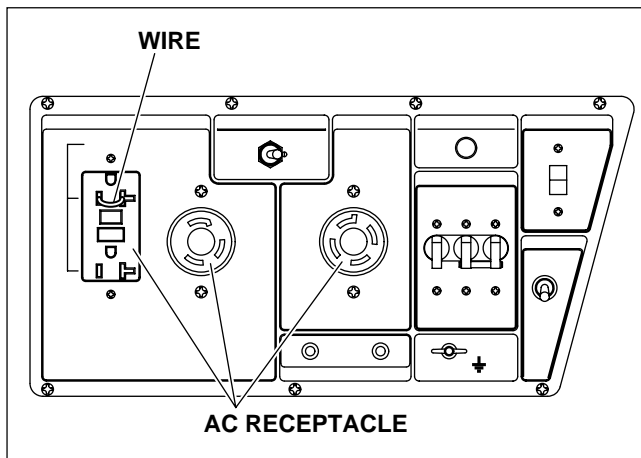

Fig. 9-2A

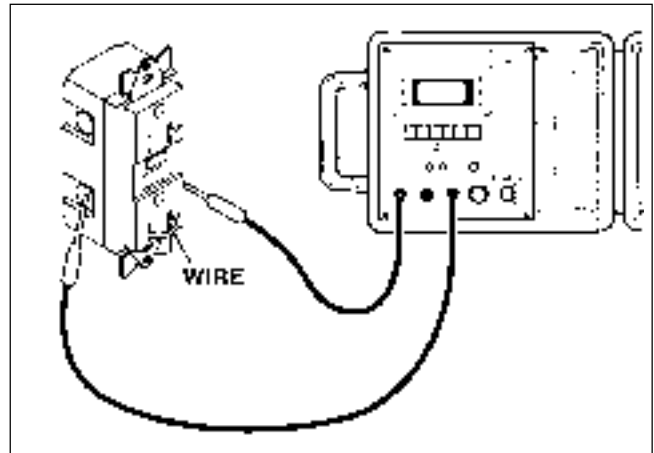

Fig. 9-2B

### 9-3 No-FUSE BREAKER

Check continuity between each of two terminals at the rear of the no-fuse breaker while it is mounted on the control panel. Normally, there is continuity between each of the two when the no-fuse breaker is on while there is no continuity when the no-fuse breaker is off.

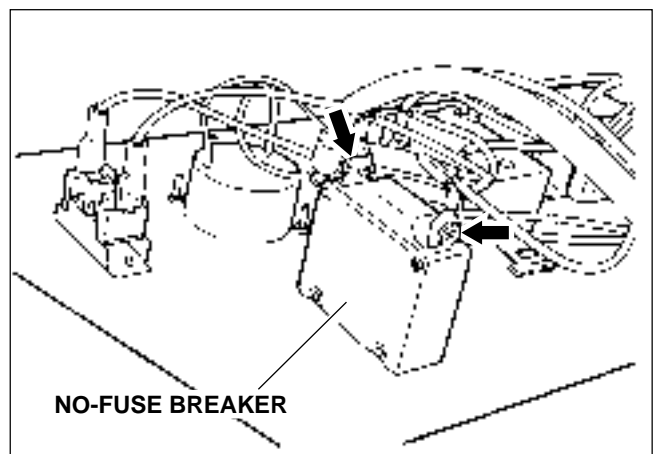

Fig. 9-3

## 9-4 STATOR

Disengage connectors on the wires from stator and check the resistance between wires with a “Dr. Robin” or a circuit tester referring to the following table.

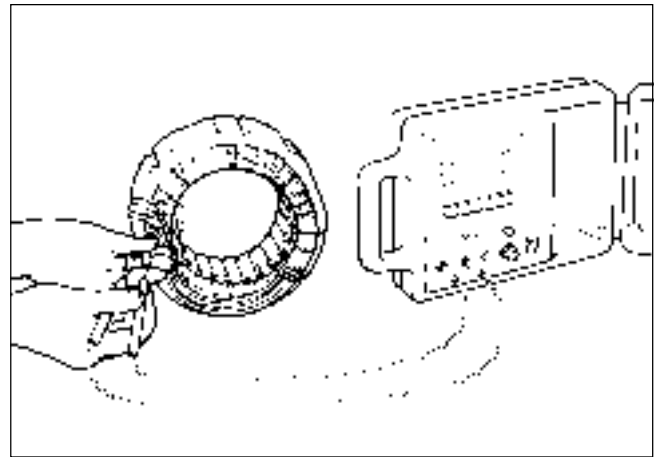

Fig. 9-4

MODEL	Specification		AC Winding		Condenser Winding
	Hz	Voltage	White / Red	Black / Blue	Yellow / Yellow
<b>RGV2800</b>	60	120 V, 120 V / 240 V	0.58	0.58	1.67
<b>RGV4100</b>	60	120 V, 120 V / 240 V	0.52	0.52	0.99
<b>RGV6100</b>	60	120 V, 120 V / 240 V	0.25	0.25	0.58

Table. 9-1

**NOTE :** If the circuit tester is not sufficiently accurate, it may not show the values given and may give erroneous readings. Erroneous readings will also occur when there is a wide variation of resistance among coil windings or when measurement is performed at ambient temperatures different from 20 °C (68 °F).

## 9-5 ROTOR ASSEMBLY

(1) Using a “Dr. Robin” or a circuit tester, measure the resistance of the field coil at the terminals.

( )

MODEL	RGV2800	RGV4100	RGV6100
RESISTANCE	1.75	1.77	1.60

Table. 9-2

### NOTE 1 :

Because a diode is soldered to the coil ends at the terminals, resistance may be measured only when tester probes touche the terminals in one combination of polarity. Therefore, if no resistance reading appears, try checking in reverse polarity.

### NOTE 2 :

If the circuit tester is not sufficiently accurate, it may not show the values given and may give erroneous readings. Erroneous reading will also occur when there is a wide variation of resistance among coil windings or when measurement is performed at ambient temperatures different from 20 °C (68 °F).

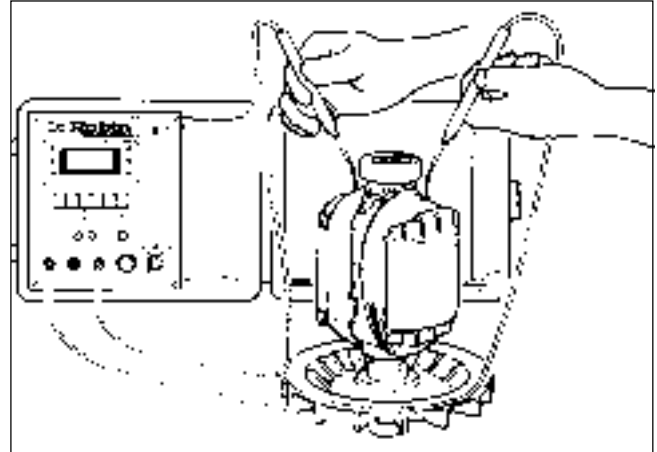

Fig. 9-5

## 9-6 CONDENSER

Use a “Dr. Robin” in capacitance meter mode to check the capacity of condensers.

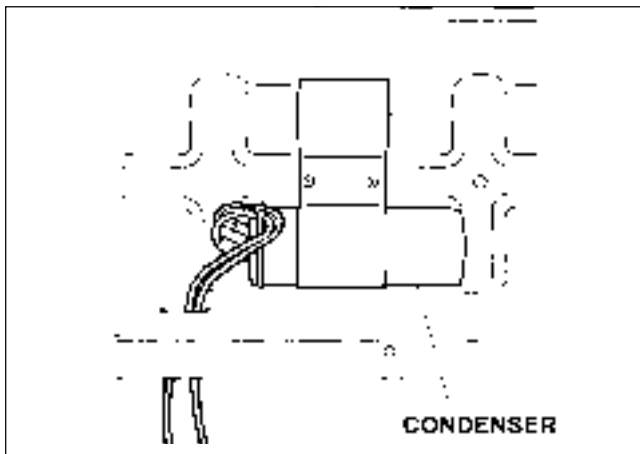

Fig. 9-6A Type RGV2800

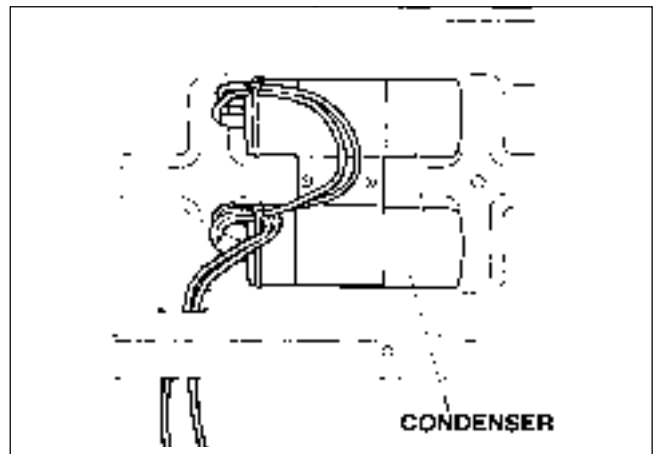

Fig. 9-6B Type RGV4100, RGV6100

**NOTE :** Be sure to discharge condensers by shorting condenser leads each other before checking their capacitance, or the accurate reading cannot be obtained.

NORMAL CAPACITY OF CONDENSER		
RGV2800	RGV4100	RGV6100
24 $\mu$ F	20 $\mu$ F x 2	28 $\mu$ F x 2

Table. 9-3

\* If such an instrument is unavailable, the condenser can be checked by replacing with a new one. If the generator performs good with new condenser, the cause of trouble is defect in original condenser.

## 9-7 DIODE RECTIFIER

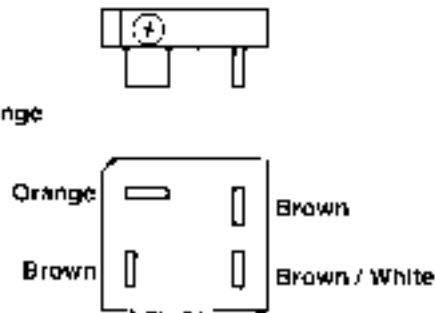
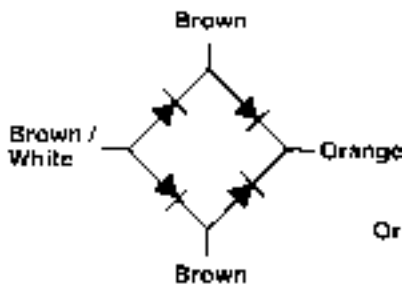
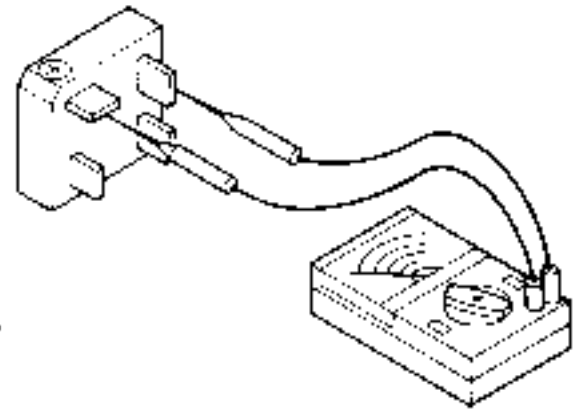

Fig. 9-7

## DIODE RECTIFIER



CIRCUIT TESTER

Fig. 9-8

Circuit inside of the diode rectifiers is as shown in Fig. 9-7. Check continuity between each terminal by using a circuit tester as shown in Fig. 9-8. The rectifier is normal when continuity is as follows:

### \* Checking table for analogue circuit tester.

Analogue circuit tester		Apply black (minus) needle of the circuit tester			
		Brown	Brown	Orange	Brown / White
Apply red (plus) needle of the circuit tester	Brown	—	No continuity	No continuity	Continuity
	Brown	No continuity	—	No continuity	Continuity
	Orange	Continuity	Continuity	—	Continuity
	Brown / White	No continuity	No continuity	No continuity	—

Table. 9-4-1

**\* Checking table for digital circuit tester.**

Digital circuit tester		Apply red (plus) needle of the circuit tester			
		Brown	Brown	Orange	Brown / White
Apply black (minus) needle of the circuit tester	Brown	—	No continuity	No continuity	Continuity
	Brown	No continuity	—	No continuity	Continuity
	Orange	Continuity	Continuity	—	Continuity
	Brown / White	No continuity	No continuity	No continuity	—

Table. 9-4-2

*NOTE 1 : Because of the difference of measuring method between the analogue circuit tester and the digital circuit tester, polarity of tester needles should be reversed.*

*NOTE 2 : "Continuity" means forward direction characteristics of the diode, and different from short circuit condition (in which a pointer of the tester goes out of its normal scale), shows resistance to some extent. When results of the checking indicates failure even in one section, replace with a new one.*

*NOTE 3 : Simpson brand analogue testers have the characteristics as same as the digital circuit tester.*

**9-8 OIL SENSOR**

- (1) Disconnect two (2) wires coming from the sensor at the connection.
- (2) Loosen the sensor to remove it from the engine.
- (3) Plug the opening of oil filler hole (created after sensor is removed) with suitable means such as oil gauge.
- (4) Connect the removed wires again with the oil sensor.
- (5) Start the engine with the oil sensor removed and confirm if ;
  - a. Engine stops after 5 seconds which is normal, or
  - b. Engine does not stop after more than 10 seconds which is unusual.

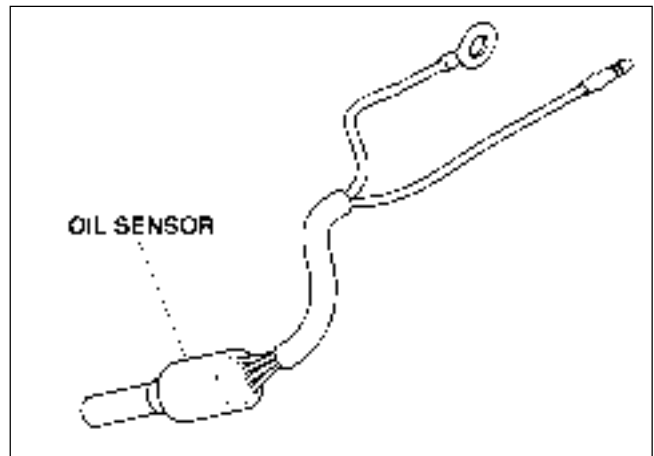

Fig. 9-9

*NOTE : The sensor will not operate properly when wire is broken or poorly connected. Check the wires for correct connection. If it fails to stop within 5 seconds after the wirings have checked, the sensor is wrong. Replace the sensor with new one.*

## **10. DISASSEMBLY AND ASSEMBLY**

### **10-1 PREPARATION and PRECAUTIONS**

- 1) Be sure to memorize the location of individual parts when disassembling the generator so that the generator can be reassembled correctly. Tag the disassembled part with the necessary information to facilitate easier and smoother reassembly.
- 2) For more convenience, divide the parts into several groups and store them in boxes.
- 3) To prevent bolts and nuts from being misplaced or installed incorrectly, replace them temporarily to their original position.
- 4) Handle disassembled parts with care; clean them before reassembly using a neutral cleaning fluid.
- 5) Use all disassembly/assembly tools properly, and use the proper tool for each specific job.



## 10-2 DISASSEMBLY PROCEDURES

Step	Part to remove	Description	Remarks	Tool
1	Control box	(1) Take off the bushing from the bottom of the control box. (See Fig. 10-1.)		
		(2) Disconnect the connectors on the wiring from the control box to the alternator. (See Fig. 10-1.)	Press the upper end of the bushing and pull out.	
		(3) Disconnect the connectors on the wiring between from the control box and the engine. (See Fig. 10-2.)		

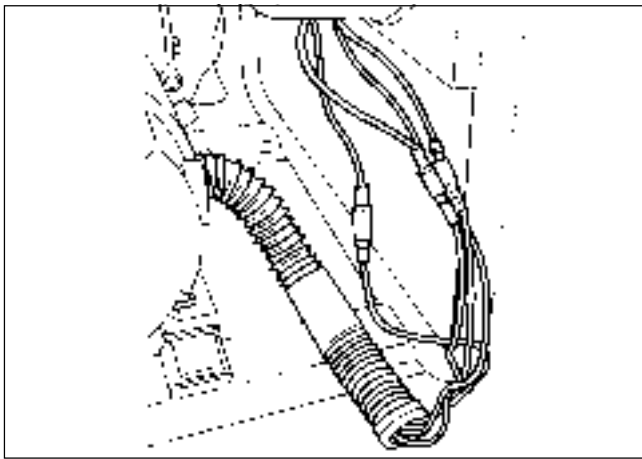

Fig. 10-1

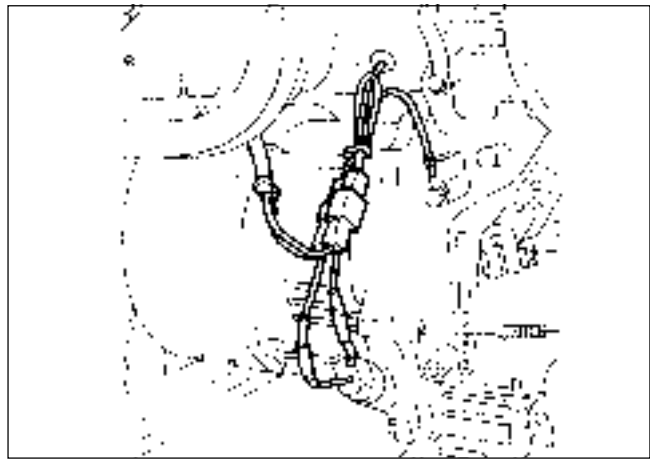

Fig. 10-2

- (4) Take off the four bolts and remove the control box the frame. (See Fig. 10-3.)  
 5 x 12 mm bolt and washer Ass'y (black) . . . 2 pcs.  
 5 x 25 mm bolt and washer Ass'y (black) . . . 2 pcs.

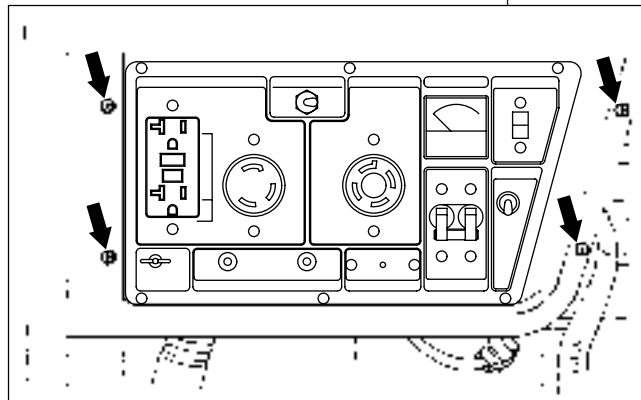
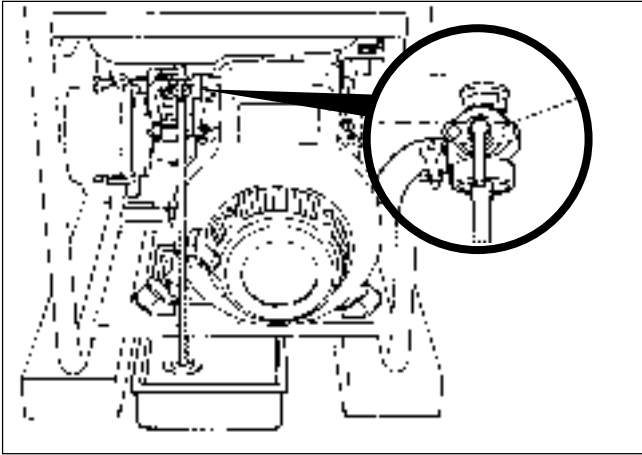

Fig. 10-3

8 mm Spanner

Step	Part to remove	Description	Remarks	Tool
2	Fuel Tank	<p>(1) Discharge fuel from the tank.</p> <ol style="list-style-type: none"> <li>1. Shut the fuel strainer.</li> <li>2. Remove the strainer cup.</li> <li>3. Put a vessel to receive fuel under the strainer and open the fuel cock to discharge fuel. (See Fig. 10-4.)</li> <li>4. Attach the strainer cup to the strainer body.</li> </ol>  <p style="text-align: center;"><i>Fig. 10-4</i></p>	<p>Use utmost care about fire hazard.</p> <p>Wipe off split fuel thoroughly.</p> <p>Do not lose the filter screen.</p>	
		<p>(2) Disconnect rubber pipe from the strainer. Loosen the hose clamp on the top of the strainer and pull out the rubber pipe from the strainer.</p>		Pliers
		<p>(3) Take off the four bolts and rubber (fuel tank) and then remove the fuel tank. (See Fig. 10-6.)</p>		10 mm spanner or box wrench

Step	Part to remove	Description	Remarks	Tool
3	Muffler and Muffler cover	<p>(1) Remove the two bolts which fix the muffler to the alternator. Loosen the two nuts on the muffler flange and remove the muffler from the engine.</p> <p>8 x 20 mm bolt and washer Ass'y . . . 2 pcs.  8 mm stainless nut . . . 2 pcs.  8 mm spring washer . . . 2 pcs.  for RGV4100 and RGV6100  Muffler gasket . . . 1 pce.</p>		12 mm spanner or box wrench
		<p>(2) Remove the muffler cover 1 and the muffler cover 2 from the muffler.</p> <p>6 x 10 mm bolt and washer Ass'y . . . 8 pcs.  (See Fig. 10-8.)</p>		10 mm spanner or box wrench
		<p>(3) Remove the muffler bracket from the rear cover.</p> <p>8 x 20 mm bolt and washer Ass'y . . . 2 pcs.</p>		12 mm spanner or box wrench

MUFFLER COVER 1

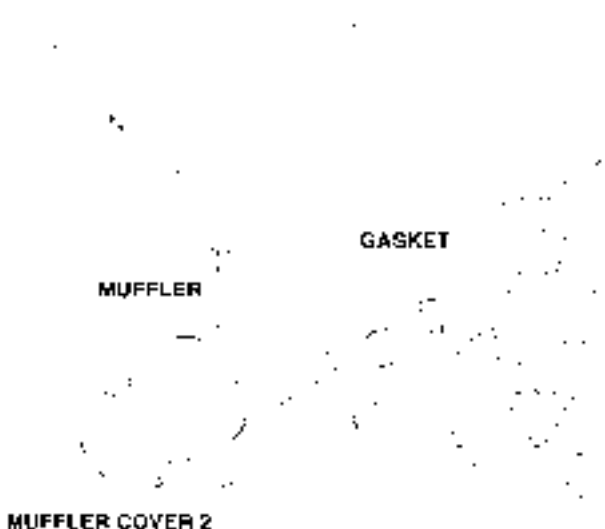

GASKET

MUFFLER

MUFFLER COVER 2

MUFFLER BRACKET  
for RGV2800, RGV6100

Fig. 10-8

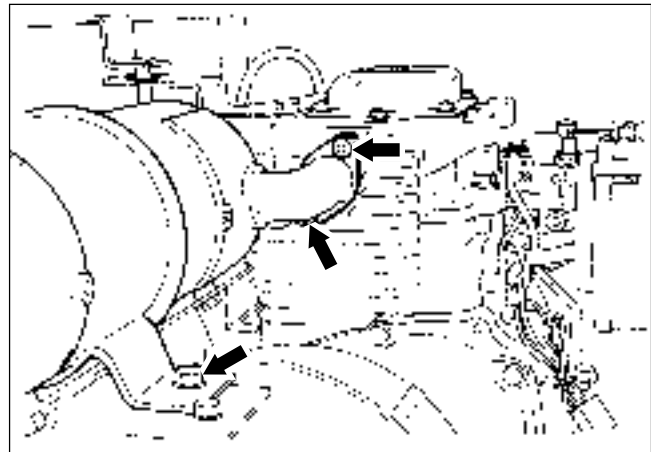
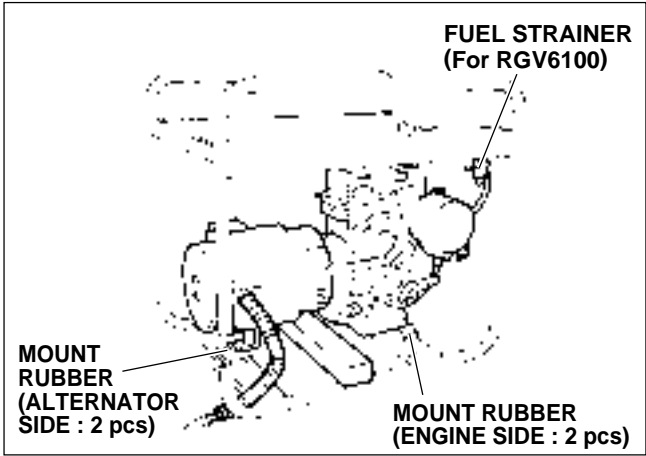
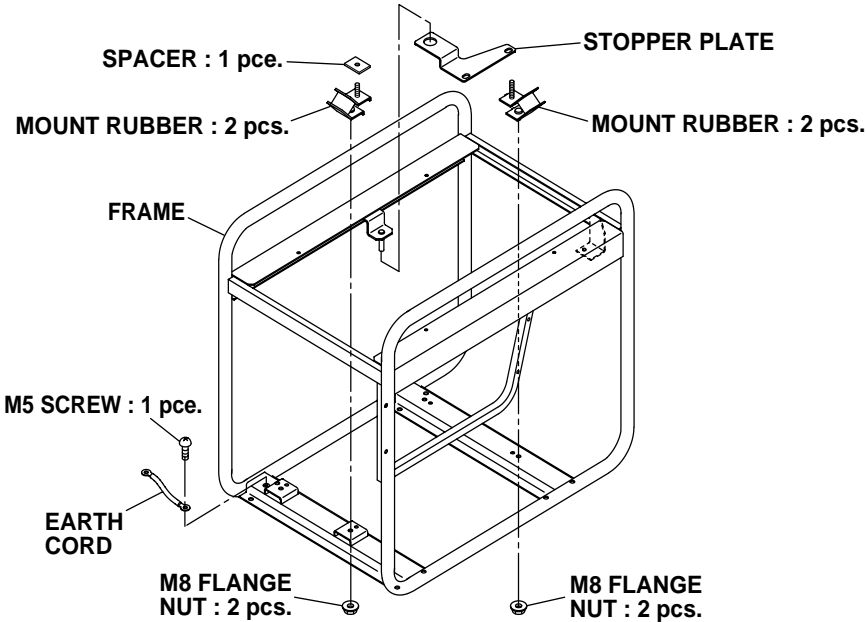

Fig. 10-7

Step	Part to remove	Description	Remarks	Tool
4	Pipe Frame	<p>(1) For RGV6100 Remove the fuel strainer from the frame.</p> <p>(2) Remove the nuts which are fixing engine and alternator to the mount rubbers. (See Fig. 10-9.)</p> <p>(3) Using a chain-block, sling up the engine and alternator and dismount from the frame.</p>  <p style="text-align: center;"><i>Fig. 10-9</i></p>	<p>Remove the air cleaner cover for dismounting.</p>	<p>10 mm spanner</p> <p>12 mm spanner</p>
		<p>(4) Remove the mount rubbers from the frame. Loosen the nuts on the bottom side of the frame. (See Fig. 10-10.)</p> <p>M8 flange nut . . . 4 pcs.</p>  <p style="text-align: center;"><i>Fig. 10-10</i></p>		<p>12 mm spanner or socket wrench</p>

Step	Part to remove	Description	Remarks	Tool
5	Rear cover	(1) Remove the end cover.(See Fig. 10-11.) (Except RGV6100) 6 bolt . . . 3 pcs.		10 mm spanner or box wrench
		(2) Remove the four bolts which fasten the rear cover to the front cover. (See Fig. 10-12.) 6 bolt . . . 4 pcs.		10 mm spanner or box wrench

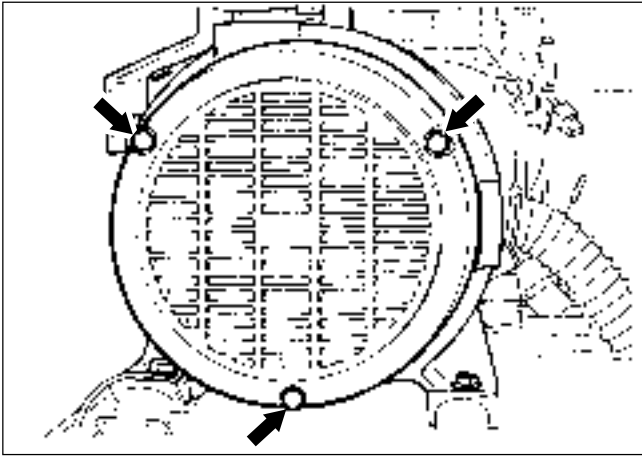

Fig. 10-11

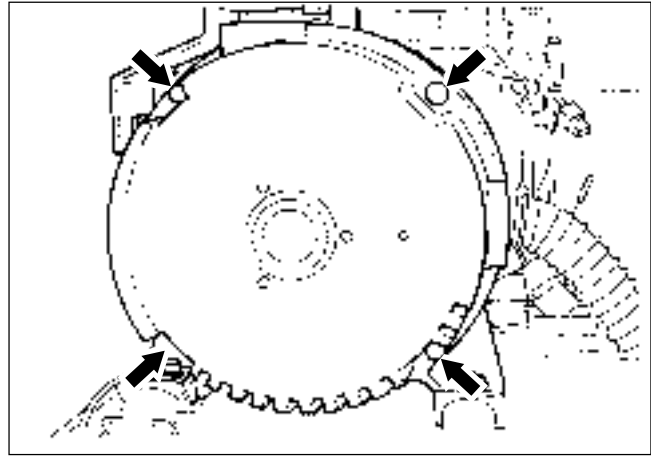

Fig. 10-12

(3) Remove the rear cover by hitting on the legs of rear cover with a plastic hammer to loosen.

Do not give a strong hit on the boss or legs.

Plastic hammer

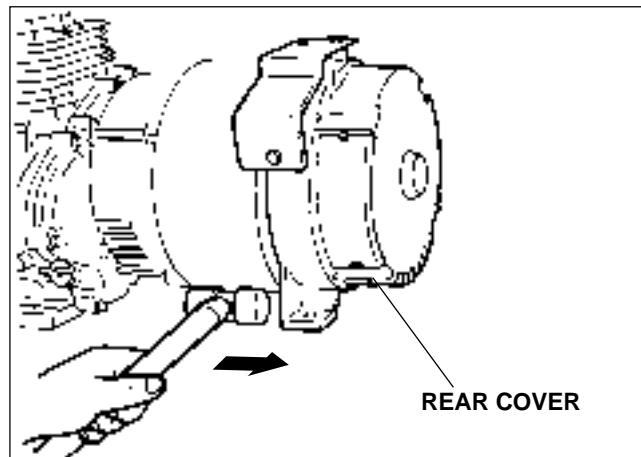
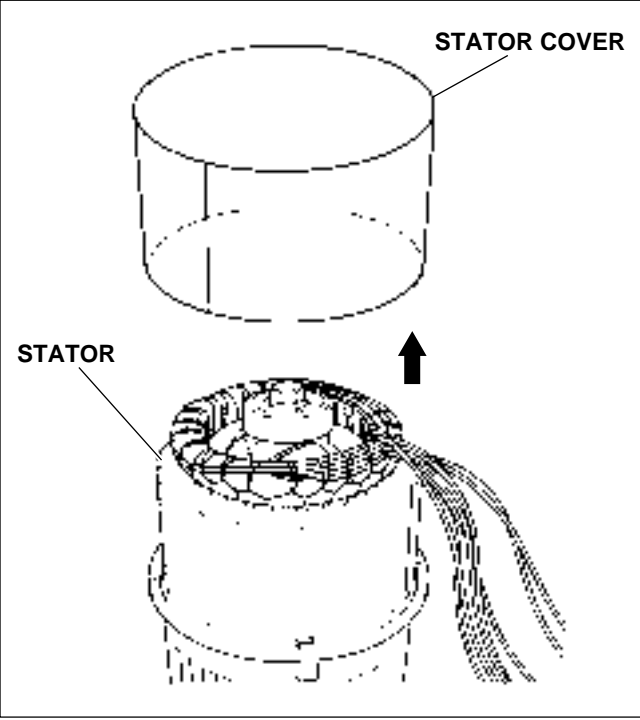
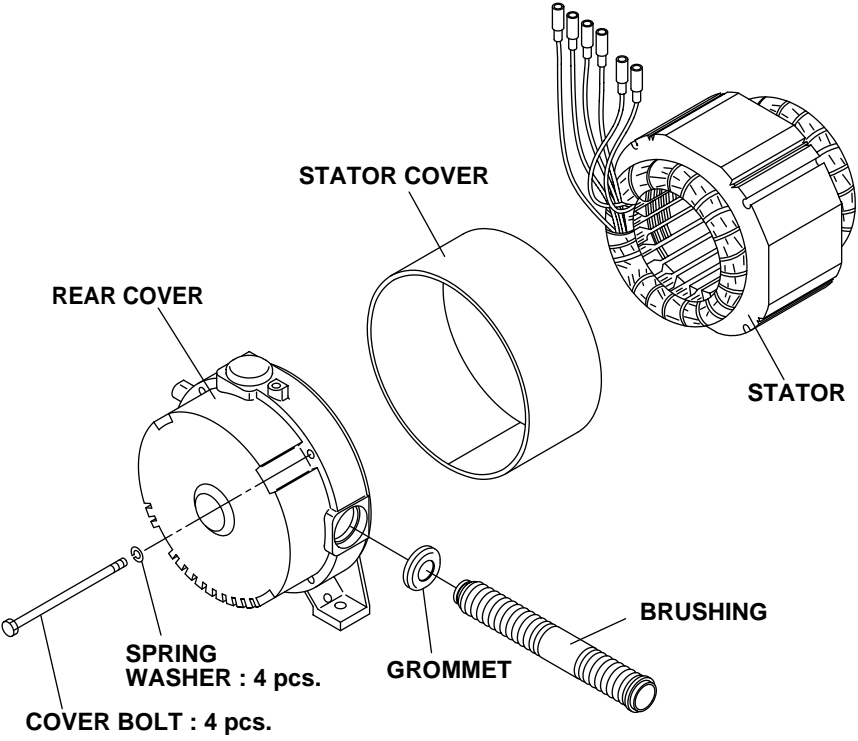
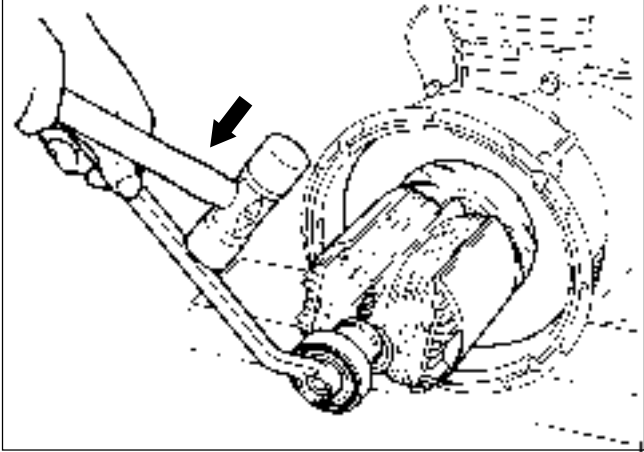
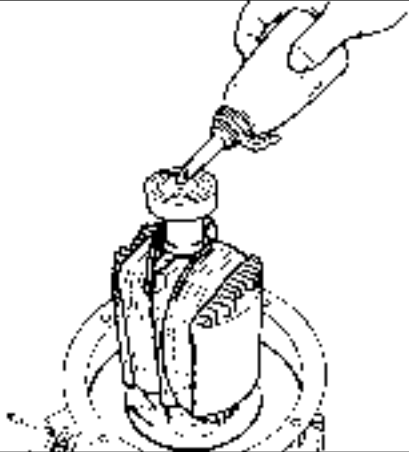
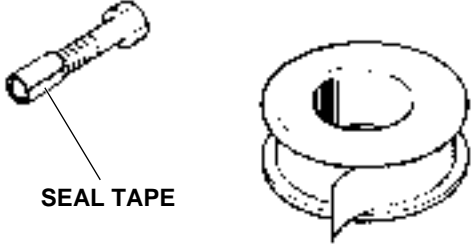
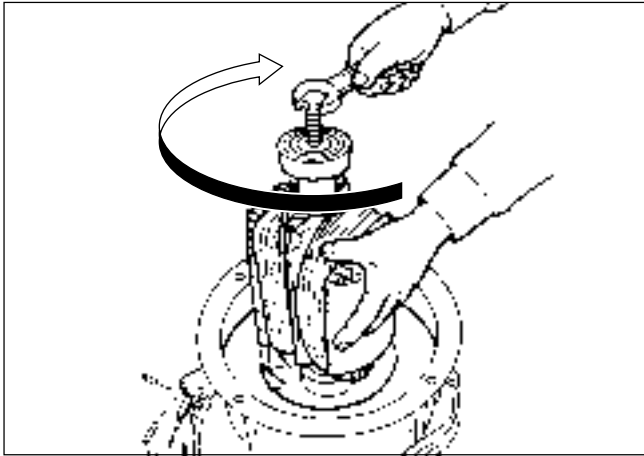
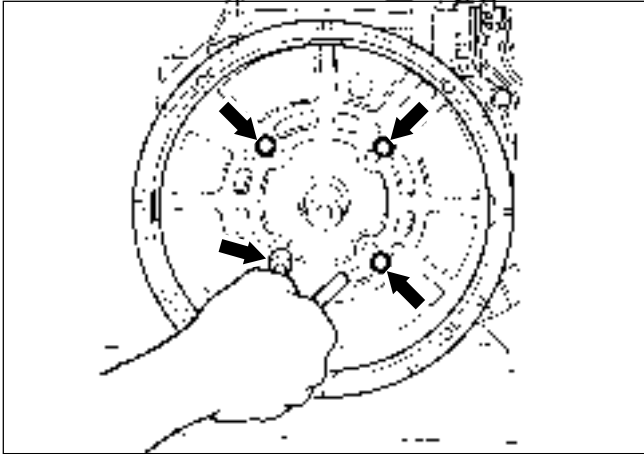

Fig. 10-13

Step	Part to remove	Description	Remarks	Tool
6	Stator	<p>(1) Remove the stator cover.</p>  <p style="text-align: center;"><i>Fig. 10-14</i></p>  <p style="text-align: center;"><i>Fig. 10-15</i></p>		

Step	Part to remove	Description	Remarks	Tool
7	Rotor	<p>(1) Take off the through bolt. Apply a box wrench on the head of through bolt. Hit the wrench handle with a hammer counter-clockwise to loosen.</p>  <p style="text-align: center;"><i>Fig. 10-16</i></p>		Box wrench Plastic hammer
		<p>(2) Put the engine on the working table recoil starter side down.</p>		
		<p>(3) Use a bolt and oil as a tool for pulling out rotor in the following procedures :</p> <ol style="list-style-type: none"> <li>1. Pour engine oil into the center hole of rotor shaft. Fill with oil to the shaft end. (See Fig. 10-17.)</li> <li>2. Prepare a bolt with the following thread size : RGV2800 . . . M10 x P 1.5 RGV4100, 6100 . . . M12 x P 1.5</li> <li>3. Apply a few turns of seal tape around the tip of the bolt. (See Fig. 10-18.)</li> </ol>		
				
				
		<i>Fig. 10-17</i>		
			<i>Fig. 10-18</i>	

Step	Part to remove	Description	Remarks	Tool
7	Rotor	<p>4. Screw the bolt into the thread of the rotor shaft.</p> <p>5. Torque the bolt using a socket wrench until the rotor comes off loose.</p> <p><b>* The hydraulic pressure inside the rotor shaft takes apart the rotor from the engine shaft.</b></p> <p>(4) Wipe off oil thoroughly from rotor shaft and engine PTO shaft.</p>  <p style="text-align: center;"><i>Fig. 10-19</i></p>	<p>Do not stick out your face over the rotor. It may jump up on separation.</p>	<p>Socket wrench</p>
8	Front Cover	<p>(1) Remove the front cover. Loosen the four bolts and remove the front cover.</p> <p>M8 x 20mm bolt and washer Ass'y . . . 4 pcs.</p>  <p style="text-align: center;"><i>Fig. 10-20</i></p>		<p>12 mm socket wrench</p>



## 10-3 ASSEMBLY PROCEDURES

### 10-3-1 FRONT COVER

Attach the front cover to the engine main bearing cover. Match the faucet joint and tighten the bolts.

M8 x 20 mm bolt . . . 4 pcs.

M8 spring washer . . . 4 pcs.

Tightening torque	
	<b><u>11.8 - 13.7 N-m</u></b>
	120 - 140 kg-cm
	8.7 - 10.1 ft-lb

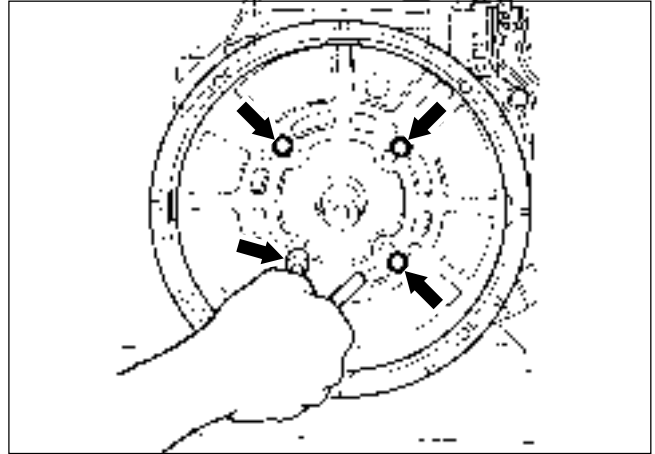

Fig. 10-21

### 10-3-2 ROTOR

(1) Wipe off oil, grease and dust from the tapered portion of engine shaft and matching tapered hole of rotor shaft.

(2) Mount the rotor to the engine shaft. Tighten the through bolt. Apply a wrench on the through bolt and hit wrench handle clockwise with a hammer to tighten. If an impact wrench is available, use it.

Tightening torque :

Tightening torque	
<b>RGV2800</b>	<b><u>11.3 - 13.2 N-m</u></b>
	115 - 135 kg-cm
	8.7 - 10.8 ft-lb
<b>RGV4100</b> <b>RGV6100</b>	<b><u>22.5 - 24.5 N-m</u></b>
	230 - 250 kg-cm
	16.6 - 19.5 ft-lb

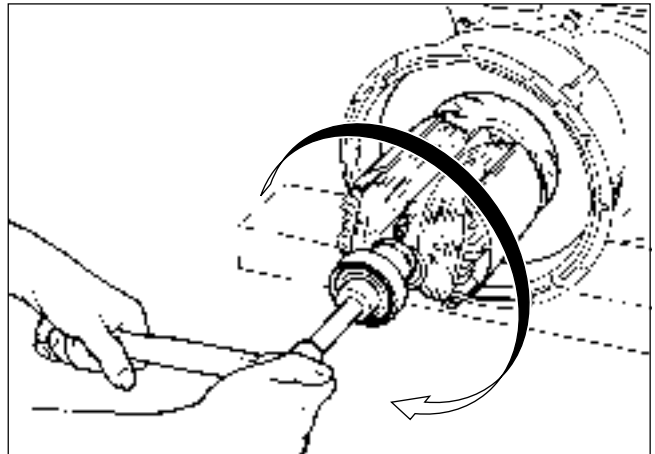

Fig. 10-22

### 10-3-3 STATOR

- (1) Put the stator in the rear cover setting the four grooves on the side of stator with thread holes of the rear cover.
- (2) Attach the stator cover around the stator.

### 10-3-4 REAR COVER

- (1) Put the rear cover with stator over the rotor. Tap on the rear cover evenly with a plastic hammer to press the rotor bearing into the rear cover.
- (2) Fix the rear cover to the adaptor with four bolts, spring washers, and washers.

RGV6100

M6 x 160 mm bolt . . . 4 pcs.

M6 spring washer . . . 4 pcs.

M6 washer . . . 4 pcs.

Tightening torque
<b>4.5 - 5.9 N-m</b>
50 - 60 kg-cm
3.6 - 4.3 ft-lb

RGV2800 and 4100

M6 x 110 mm bolt . . . 4 pcs.

M6 spring washer . . . 4 pcs.

Tightening torque
<b>4.5 - 5.9 N-m</b>
50 - 60 kg-cm
3.6 - 4.3 ft-lb

- (3) Attach the bushing over the lead wire drawn out from the rear cover. Press the smaller end of the bushing into the window of the rear cover.

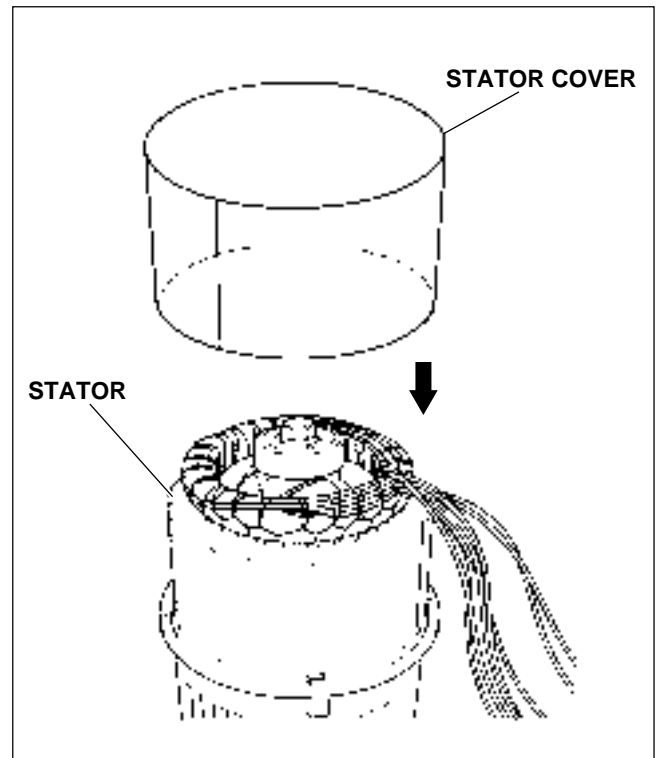

Fig. 10-23

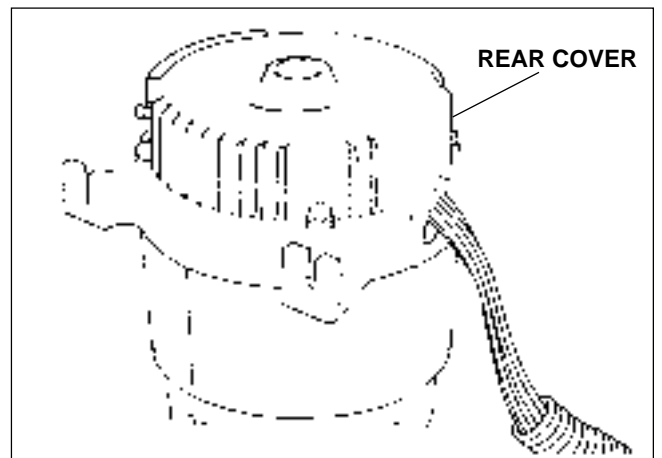

Fig. 10-24

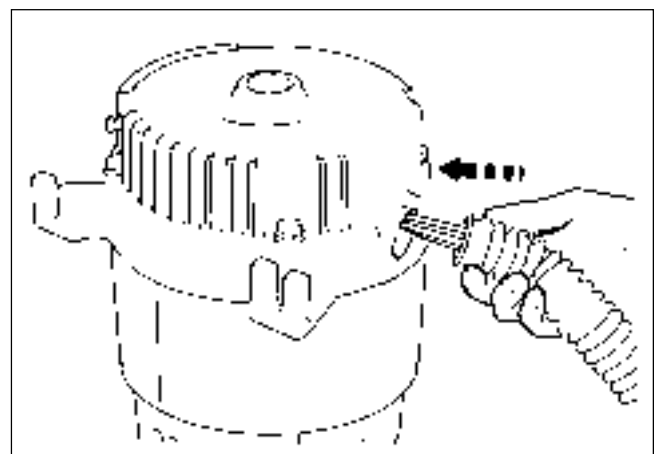

Fig. 10-25

### 10-3-5 END COVER (RGV4100 only)

Attach the end cover to the rear cover.

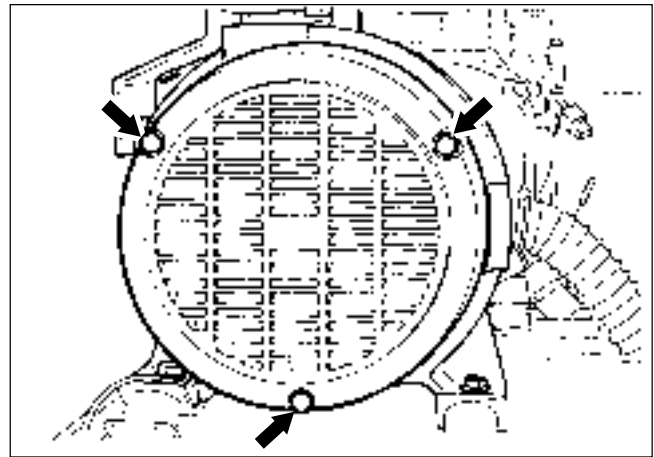

Fig. 10-26

### 10-3-6 FRAME

- (1) Attach the mount rubbers to the frame. Insert the setting tongue of mount rubber into the hole on the frame and tighten the nut from the bottom of the frame.

M8 flange nut . . . 4 pcs.

Tightening torque
<b>11.8 - 13.7 N-m</b>
120 - 140 kg-cm
8.7 - 10.8 ft-lb

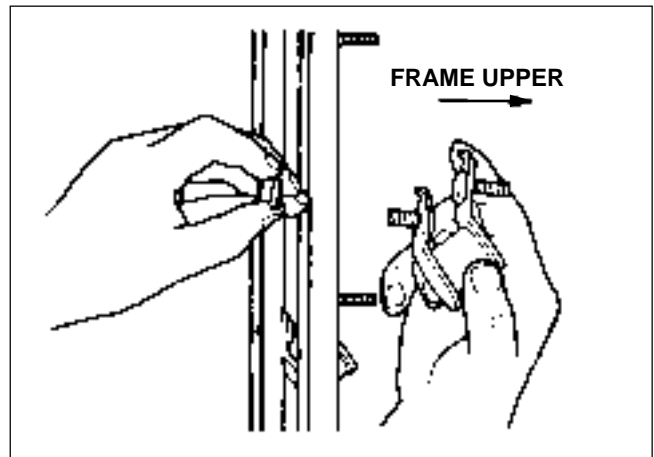

Fig. 10-27

*NOTE : The mount rubbers are selected to reduce vibration most effectively by model. Be sure to use the correct mount rubber for your generator. Although mount rubbers have the same appearance, their characteristics are different.*

- (2) Attach the 5 mm terminal of the grounding wires (green / yellow) to the unpainted thread hole of the frame base plate using a 5 mm brass screw.
- (3) Install the engine and alternator assembly into the frame. Put the engine and alternator assembly into the frame from the side of it. Tighten the nuts over the mount rubber bolts to fix.

M8 nuts . . . 4 pcs.

Tightening torque
<b>11.8 - 13.7 N-m</b>
120 - 140 kg-cm
8.7 - 10.8 ft-lb

*NOTE : Remove the air cleaner cover for easier installation.*

*NOTE : When tightening the nuts, slightly lift the engine and alternator assembly so that the weight is not applied to the mount rubbers.*

- (4) Fasten the other earth cable with 5 mm terminal to the unpainted bolt hole on the frame.  
(See Fig.10-28.)

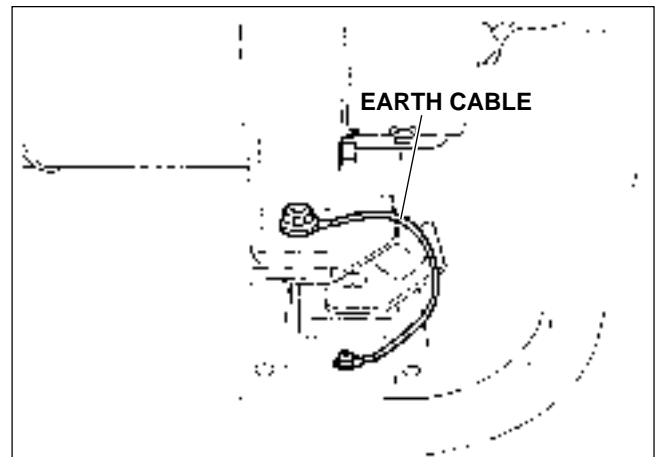

Fig. 10-28

10-3-7 MUFFLER and MUFFLER COVER

- (1) Temporarily fix the muffler bracket to either the rear or front covers for RGV6100 or RGV2800.  
M8 x 20 mm bolt and washer Ass'y . . . 2 pcs.
- (2) Attach the muffler cover 1 and the muffler cover 2 to the muffler.  
M6 x 10 mm bolt and washer Ass'y . . . 8 pcs.

Tightening torque
<b>7.9 - 9.8 N-m</b>
80 - 100 kg-cm
5.8 - 7.2 ft-lb

- (3) Put the muffler gasket to the engine.
- (4) Attach the muffler with muffler cover to the engine and the rear cover .
- ① Tighten the two nuts for the muffler first. Use the spring washers for RGV4100 and RGV6100.  
8 mm stainless nut . . . 2 pcs.  
8 mm spring washer . . . 2 pcs.  
(for RGV4100 and RGV6100 only)

Tightening torque
<b>21.6 - 27.4 N-m</b>
220 - 280 kg-cm
15.8 - 20.2 ft-lb

- ② Tighten the bolts to fix the muffler to the rear cover.  
M8 x 20 mm bolt and washer Ass'y . . . 2 pcs.  
(for RGV4100)

Tightening torque
<b>18.6 - 24.5 N-m</b>
190 - 250 kg-cm
13.7 - 18.0 ft-lb

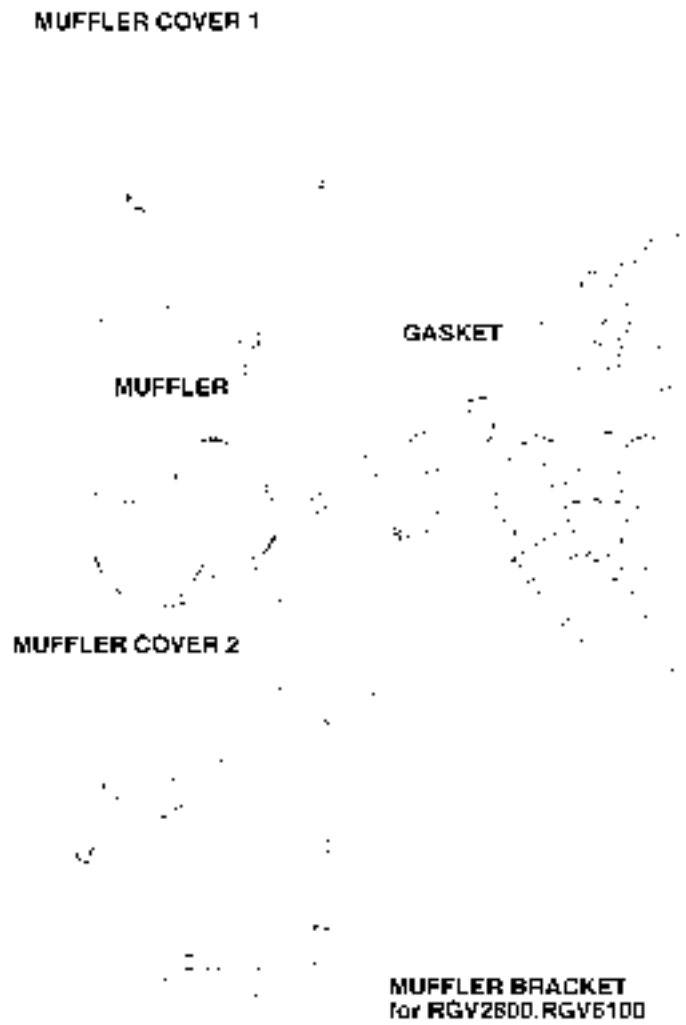

Fig. 10-29

- ③ For RGV2800 and 6100 : Tighten the two bolts to fix the muffler bracket to the front cover, rear cover, and then the two bolts for the muffler to the muffler bracket.

M8 x 20 mm bolt and washer Ass'y . . . 4 pcs. (for RGV2800 and 6100)

Tightening torque
<b>18.6 - 24.5 N-m</b>
190 - 250 kg-cm
13.7 - 18.0 ft-lb

### 10-3-8 FUEL TANK

- (1) For RGV2600 and RGV4100 only :

Attach the fuel strainer to the bottom of the fuel tank. Screw in the fuel strainer all the way and return one to two turns, and then lock it with the lock nut.

For RGV6000 only :

Attach the fuel strainer to the frame.

Tightening torque
<b>4.9 - 6.9 N-m</b>
50 - 70 kg-cm
3.6 - 5.0 ft-lb

- (2) Mount the fuel tank on the frame with rubber washers between the tank flange and the frame.

M6 x 20 mm bolt (black) . . . 4 pcs.

Rubber washer . . . 4 pcs.

*NOTE : For easy tank assembly, glue the rubber washers over the mounting holes of the frame.*

- (3) Connect the rubber pipe.

First, fit the hose clamps on the rubber pipe and connect it to the strainer and the carburetor. Then fasten it with the hose clamps.

For RGV6100, connect the rubber pipe to the strainer and the fuel tank in the same way.

*NOTE : Apply a drop of oil to the rubber pipe for easier connection.*

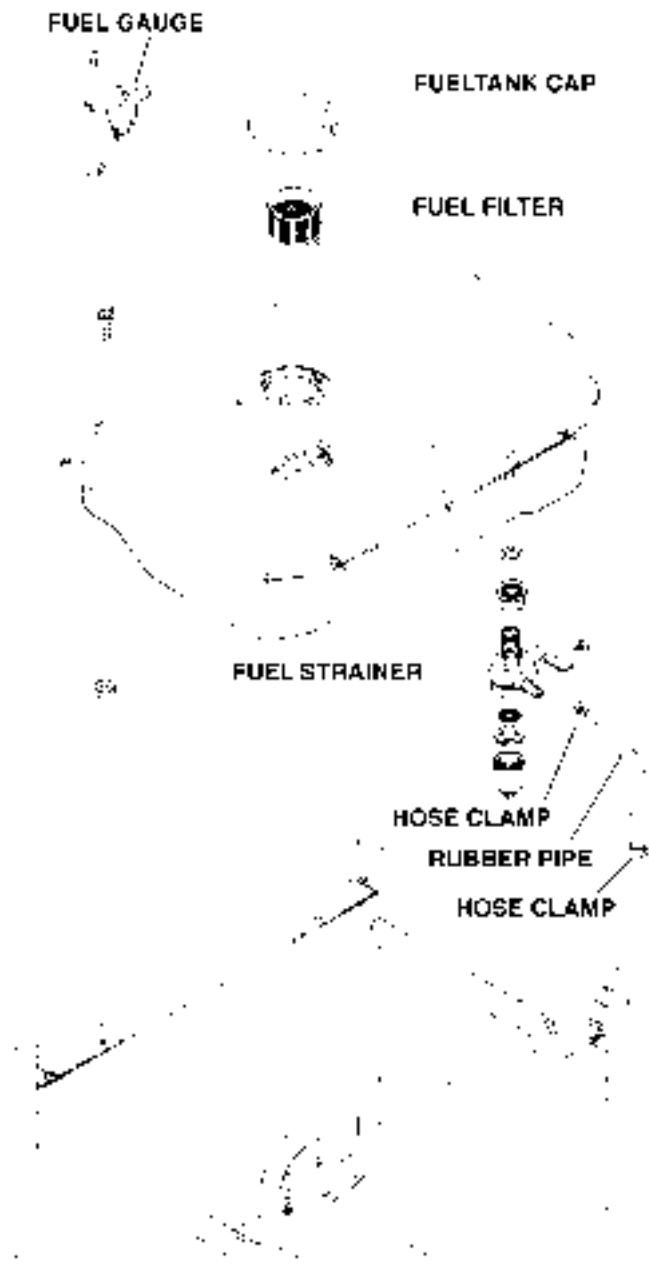

Fig. 10-30

### 10-3-9 FRONT PANEL

Mount the front panel assembly to the frame.

Refer to Section 10-4 for disassembly, checking and reassembly procedures of the front panel.

- (1) Connect the wires from the front panel and the engine.
- (2) Connect the wires drawn out from the stator to the wires from the front panel.

*NOTE : Connect the wires of the same color.*

- (3) Press the upper end of the bushing into the bottom window of the front panel.
- (4) Mount the front panel to the frame.

M5 x 12 mm bolt and washer Ass'y . . . 2 pcs.

M5 x 25 mm bolt and washer Ass'y . . . 2 pcs.

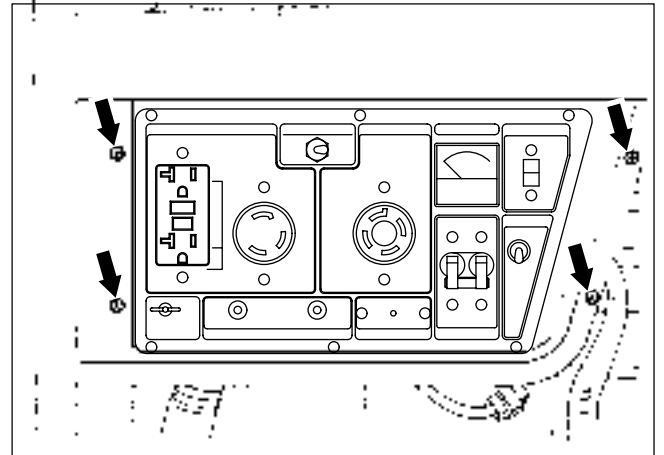

Fig. 10-31

## 10-4 CHECKING, DISASSEMBLY and REASSEMBLY of the FRONT PANEL

### 10-4-1 CHECKING OF THE FRONT PANEL

Dismount the front panel from frame. Remove the control panel and check each components and wiring. Refer to Section 9 for the detail of checking procedure for the components in the front panel.

### 10-4-2 DISASSEMBLY

- (1) Remove the control panel from the front panel.
  - M4 screw . . . 6 pcs. (RGV2800, RGV4100)
  - M4 screw . . . 7 pcs. (RGV6100)
- (2) Disconnect the connectors on the wires to detach the control panel and front panel.
- (3) Remove the condensers and diode rectifier from the front panel.
- (4) After disconnecting individual wires, remove the control panel components.

*NOTE : Full power switch and pilot lamp have their wires soldered. Unsolder them to remove those parts if necessary.*

### 10-4-3 REASSEMBLY

(1) Install the receptacles, no-fuse breaker, terminals, switches, etc. on the control panel and wire them.

*NOTE : Circuit diagrams are shown in Section 12. Colored wires are used for easy identification, and are of the correct capacity and size. Use heat-resistant type wires (permissible temperature range 75°C or over) in the specified gauge shown in the circuit diagrams.*

(2) Install condensers, and diode rectifier into the front panel.

(3) Connect the wires of control panel components and front panel.

(4) Attach the control panel to the front panel.

M4 screw . . . 6 pcs. (RGV2800, RGV4100)

M4 screw . . . 7 pcs. (RGV6100)

<b>Tightening torque</b>
<b><u>1.2 - 1.5 N-m</u></b>
12 - 15 kg-cm
8.7 - 10.9 ft-lb

# 11. TROUBLESHOOTING

## 11-1 NO AC OUTPUT

### 11-1-1 CHECKING CONDENSER

(1) Check the capacity of condensers using a “Dr. Robin” generator tester in capacitance meter mode.

*NOTE : Be sure to discharge condensers by shorting condenser leads each other before checking their capacitance, or the accurate reading cannot be obtained.*

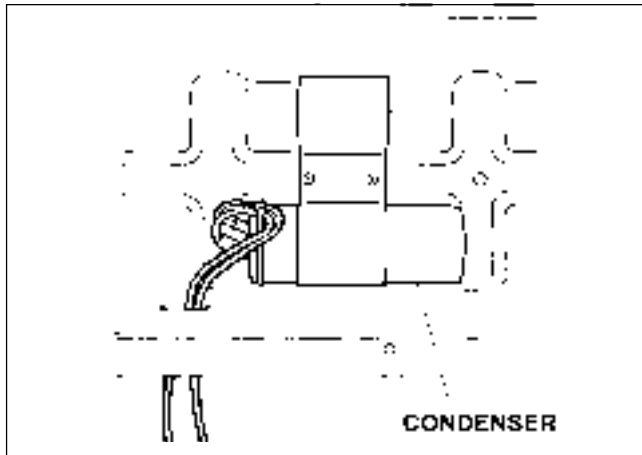

Fig. 11-1A Type RGV2800

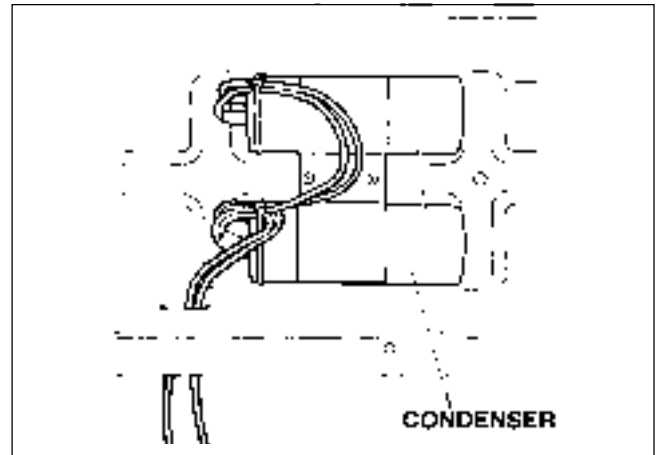

Fig. 11-1B Type RGV4100, RGV6100

NORMAL CAPACITY OF CONDENSER		
RGV2800	RGV4100	RGV6100
24 $\mu$ F	20 $\mu$ F x 2	28 $\mu$ F x 2

Table. 11-1

(2) If such an instrument is unavailable, the condenser can be checked by replacing with a new one. If the generator performs good with new condenser, the cause of trouble is defect in original condenser.

### 11-1-2 CHECKING STATOR

(1) Remove control panel and disconnect stator wires at the connectors.

(2) Measure the resistance between terminals on stator leads. (See Fig.11-2) Refer to Table 9-1 for normal resistance.

If stator is faulty, replace it with a new one.

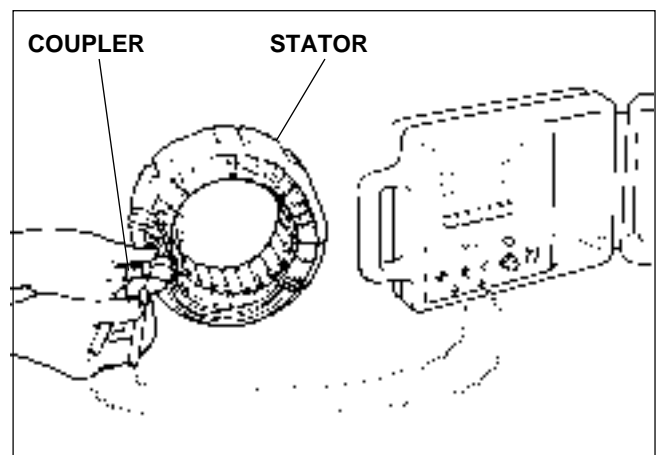

Fig. 11-2



(3) Check the insulation resistance between stator core and each stator lead using a Dr. Robin generator tester in megger tester mode or a megger tester. (Fig. 11-3)

If insulation is bad, replace stator with a new one.

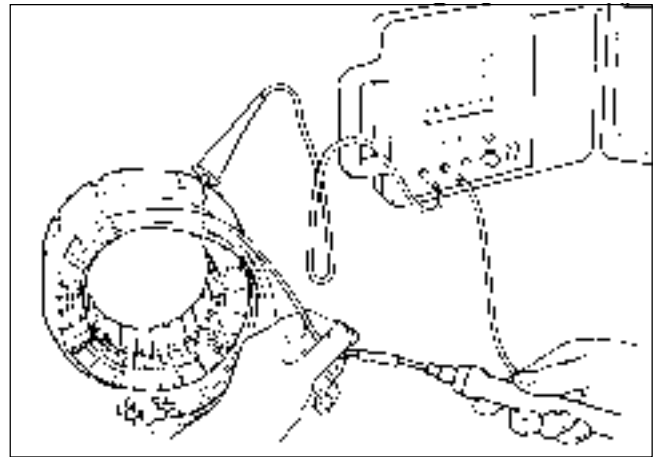

Fig. 11-3

### 11-1-3 CHECKING ROTOR

(1) Remove rear cover and stator.

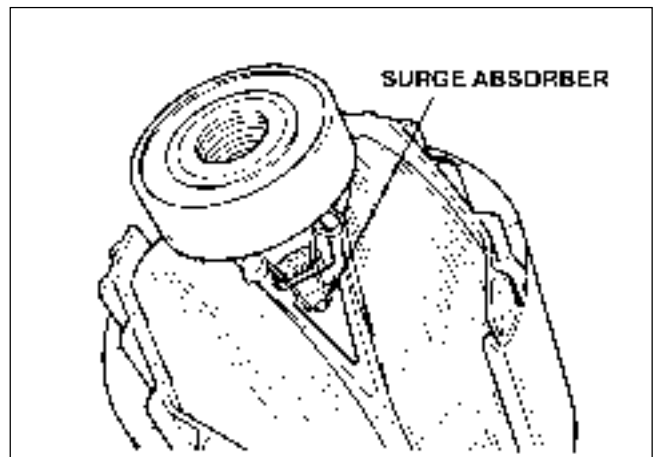

Fig. 11-4

(2) Using a Dr. Robin or a circuit tester, measure the resistance of the field coil at the terminals.

( )

MODEL	RGV2800	RGV4100	RGV6100
RESISTANCE	1.75	1.77	1.60

Table. 11-2

*NOTE : Because a diode is soldered to the coil ends at the terminals, resistance may be measured only when tester probes touch the terminals in one combination of polarity. Therefore, if no resistance reading appears, try checking in reverse polarity.*

#### [Remedy]

If the resistance is not normal, replace rotor with a new one.

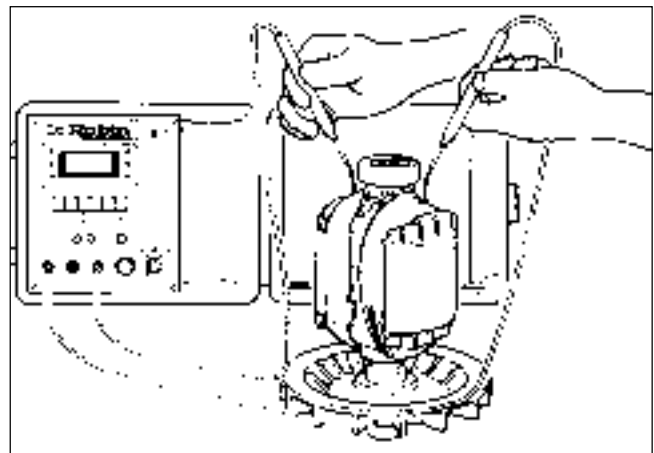

Fig. 11-5

(3) Measure the insulation across one of the soldered terminals of the rotor and the core. (Fig.11-6)

If insulation is bad, replace rotor with a new one.

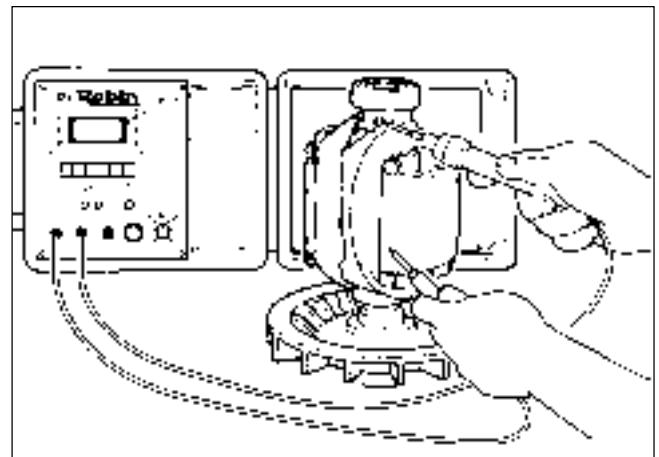

Fig. 11-6

## 11-2 AC VOLTAGE IS TOO HIGH OR TOO LOW

### 11-2-1 CHECKING ENGINE SPEED

If the engine speed is too high or too low, adjust it to the rated r.p.m.

#### [How to adjust engine r.p.m.]

- \* Loosen the lock nut on the adjusting screw.
- \* Turn the adjusting screw clockwise to decrease engine speed or counterclockwise to increase engine speed.

Normal engine speed at no load
3700 to 3750 rpm

### 11-2-2 CHECKING CONDENSER

Check condenser referring to Step 11-1-1.

### 11-2-3 CHECKING STATOR

Check stator referring to Step 11-1-2.

### 11-2-4 CHECKING ROTOR

Check rotor referring to Step 11-1-3.

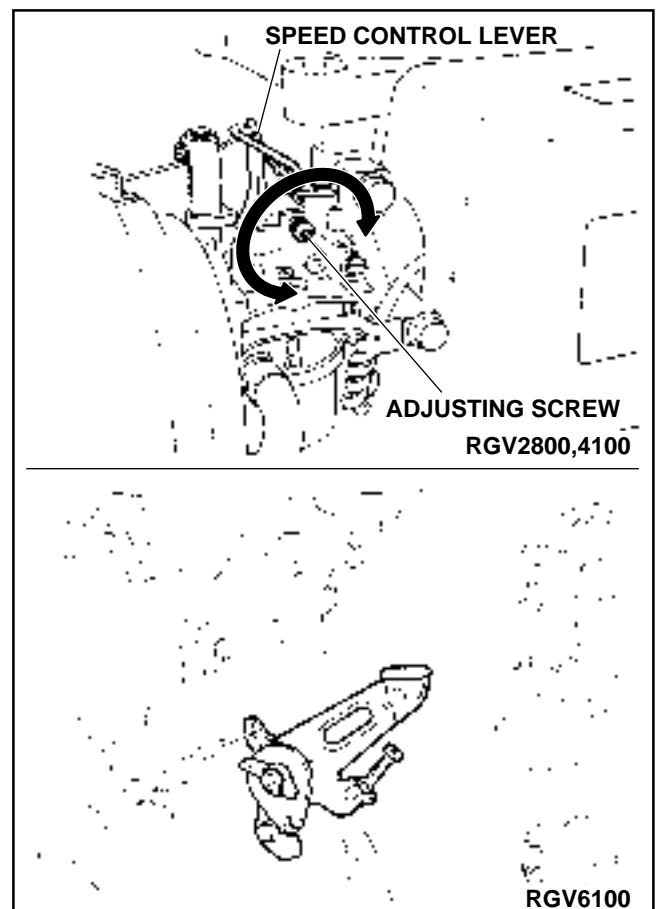

Fig. 11-7

### 11-3 AC VOLTAGE IS NORMAL AT NO-LOAD, BUT THE LOAD CANNOT BE APPLIED.

#### 11-3-1 CHECK THE ENGINE SPEED.

If the engine speed is low, adjust it to the rated r.p.m.

\*Refer to Step 11-2-1 for engine speed adjustment.

#### 11-3-2 CHECK THE TOTAL WATTAGE OF APPLIANCES CONNECTED TO THE GENERATOR.

Refer to Section 7 "RANGE OF APPLICATIONS" for the wattage of the appliances.

If the generator is overloaded, reduce the load to the rated output of the generator.

#### 11-3-3 CHECK THE APPLIANCE FOR TROUBLE.

If the appliance is faulty, repair it.

#### 11-3-4 CHECK IF THE ENGINE IS OVERHEATED.

If the cooling air inlet and/or cooling air outlet is clogged with dirt, grass, chaff or other debris, remove it.

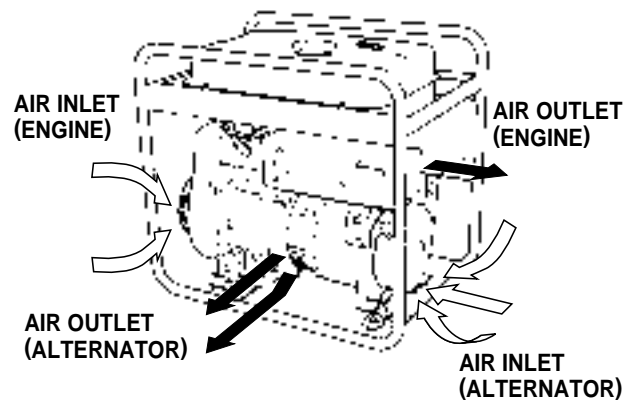

Fig. 11-8

#### 11-3-5 CHECK THE INSULATION OF THE GENERATOR.

Stop the engine. Measure the insulation resistance between the live terminal of the receptacle and the ground terminal.

If the insulation resistance is less than  $1M$  , disassemble the generator and check the insulation resistance of the stator, rotor and the live parts in the control box. (Refer to Section 8-3.)

Any part where the insulation resistance is less than  $1M$  , the insulation is faulty and may cause electric leakage.

Replace the faulty part.

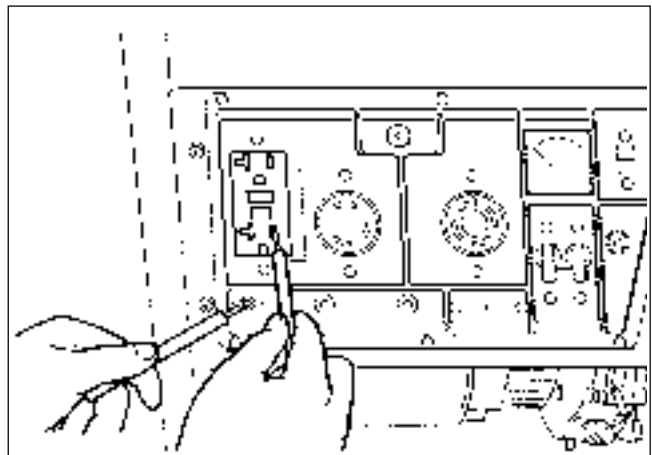

Fig. 11-9

## 11-4 NO DC OUTPUT

### 11-4-1 CHECK THE AC OUTPUT.

Check the generator by following Step 11-1-1 through Step 11-1-3.

### 11-4-2 CHECK THE DC BREAKER.

If the DC breaker turned off while charging a battery, check the cables for short-circuit or connection in reverse polarity before resetting it on.

*NOTE : If the DC output is used to charge a large capacity battery or an over-discharged battery, an excessive current may flow causing.*

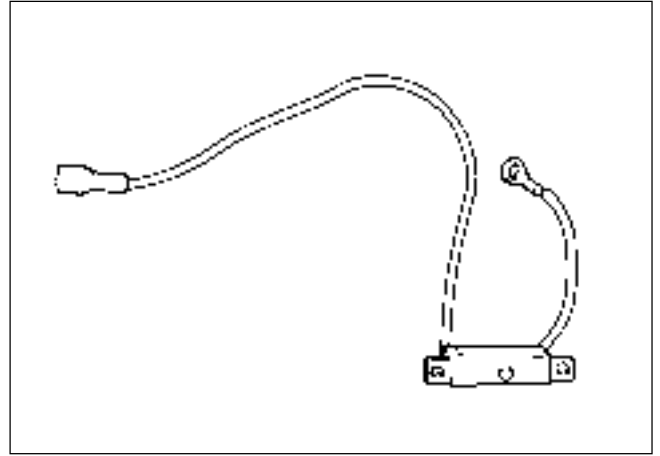

Fig. 11-10

### 11-4-3 CHECK THE DC FUSE.

Check the fuse in the fuse holder.

If the fuse is blown, check for the cause of fuse blowing, and then replace with a new one.

FUSE : 10 A

*NOTE : If the DC output is used to charge a large capacity battery or an over-discharged battery, an excessive current may flow causing fuse blow.*

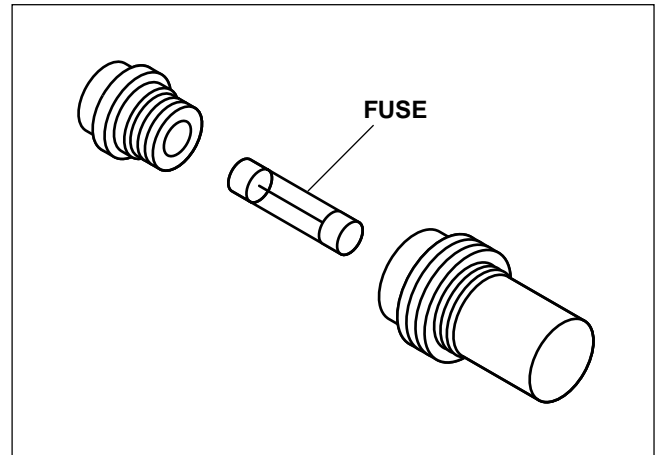

Fig. 11-11

### 11-4-4 CHECK THE WIRING.

Check all the wires to be connected correctly.

### 11-4-5 CHECK THE DIODE RECTIFIER.

Remove the control panel and check the diode rectifier with a circuit tester.

Refer to Section 9-7 "DIODE RECTIFIER" for the checking procedure.

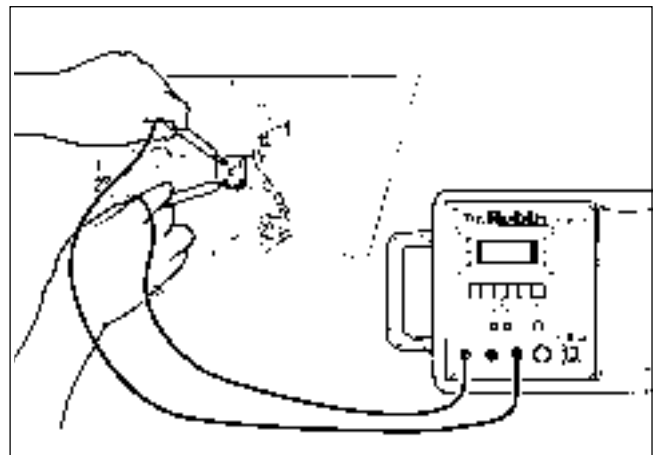

Fig. 11-12

### 11-4-6 CHECK THE DC COIL

Check the resistance between two brown leads from stator with a circuit tester.

MODEL	SPECIFICATION		RESISTANCE
RGV2800	60 Hz	120V, 120V/240V	0.25
RGV4100	60 Hz	120V, 120V/240V	0.18
RGV6100	60 Hz	120V, 120V/240V	0.13

Table. 11-3

If the resistance reading is much larger or smaller than the specified value, the DC coil of the stator is faulty. Replace stator with a new one.

### 11-5 IDLE CONTROL

#### 11-5-1 ENGINE SPEED IS NOT INCREASED WHEN A LOAD IS APPLIED

- (1) Inspect the solenoid bracket. Check the bend angle of solenoid bracket. If the bracket is distorted, correct the angle with proper tool.
- (2) Check the wattage of load applied to the generator. If the generator is loaded over the rated wattage, the engine speed can not be increased. Most induction loads such as electric motor or electric tools or welding machine require three to five times large wattage of their ratings at starting. This starting wattage must not exceed the rated output of the generator.
- (3) Check the slow set r.p.m.

The normal idling speed by the IDLE CONTROL is as follows :

RGV2800 ..... 1900 to 2100 r.p.m.

RGV4100, 6100 ..... 2000 to 2200 r.p.m.

The above speed setting is for cold engine condition. If the engine speed is out of adjusting range of the adjusting screw, move the solenoid backward.

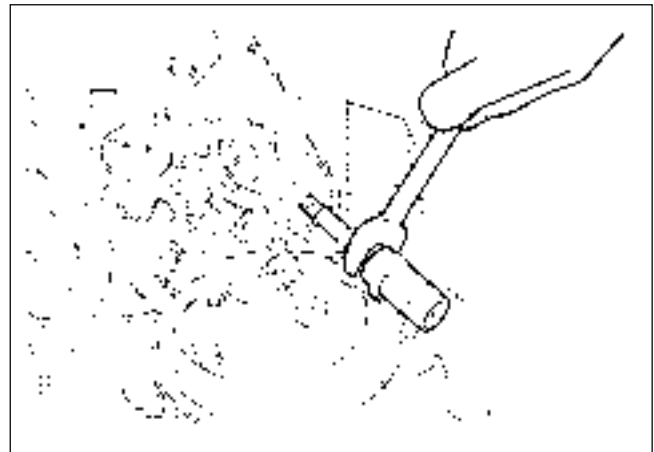

Fig. 11-13

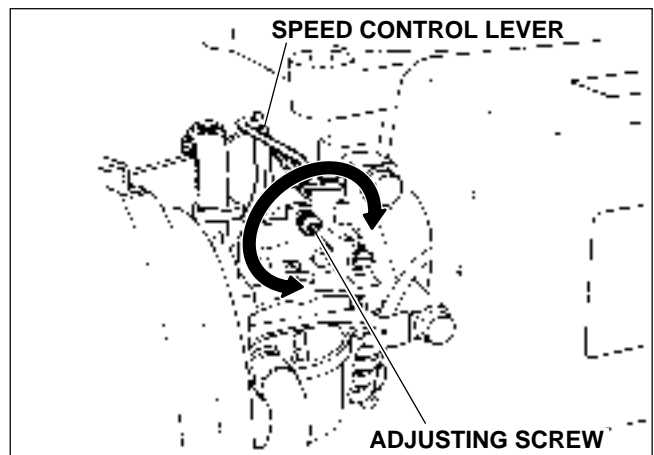

Fig. 11-14

(4) Check the wiring through ZCT on the IDLE CONTROL UNIT.

**\* Single Voltage Type**

Make sure that an output wire from main coil is passing through the ZCT on the IDLE CONTROL UNIT.

**\* Dual Voltage Type**

Check that two output wires (black wire and red wire) from main coils are passing through the ZCT on the IDLE CONTROL UNIT in the same direction.

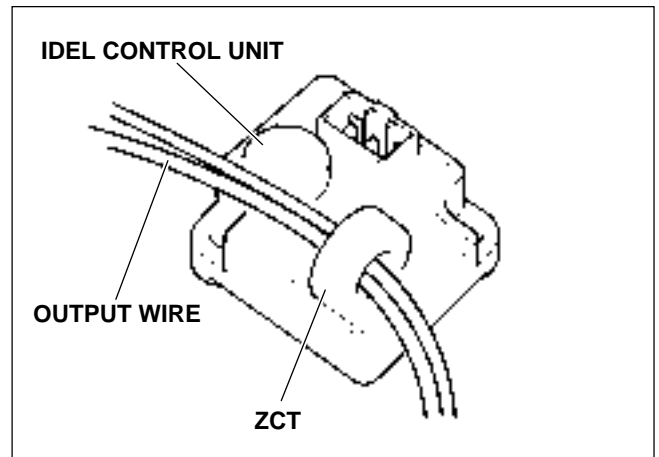
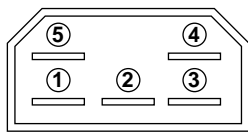

Fig. 11-15

(5) Checking the IDLE CONTROL UNIT

Check the resistance between five leads of IDLE CONTROL UNIT with circuit tester.



Terminal number of the IDEL CONTROL UNIT

Fig. 11-16A

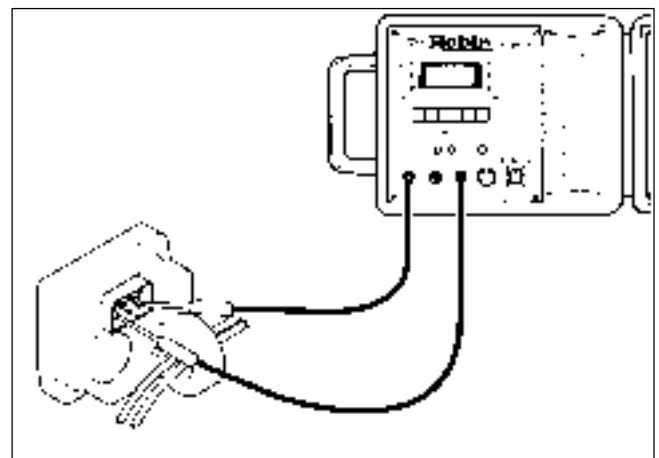

Fig. 11-16B

Circuit tester (with battery power source 1.5 V)		Apply black (minus) needle of the circuit tester				
		1	2	3	4	5
Apply red (plus) needle of the circuit tester	1	—		250 k	250 k	75 k
	2		—			
	3	250 k		—	250 k	75 k
	4	250 k		250 k	—	75 k
	5	8.5 k		7.8 k	7.8 k	—

Table. 11-4

**NOTE :** The resistance readings vary depending on the types of circuit testers. The above table shows an example of the resistance readings measured by an ordinary analogue circuit tester with 1.5 volt battery power source. It is advisable for you to check the resistance readings using your standard circuit tester and revise the checking table.

**11-5-2 ENGINE SPEED IS NOT REDUCED WHEN LOAD IS OFF.**

(1) Check the distortion of the SOLENOID BRACKET as shown in step 11-5-1-(1).

(2) Check the wiring of SOLENOID.

Check two leads from SOLENOID are securely connected.

(3) Check the wiring of IDLE CONTROL UNIT.

Check all leads from IDLE CONTROL UNIT are securely and correctly connected.

(4) Checking the SOLENOID.

Measure the resistance between two leads from SOLENOID.

Normal Resistance
25 - 31

If the resistance is larger or smaller than this range, SOLENOID is defective, Replace with a new one.

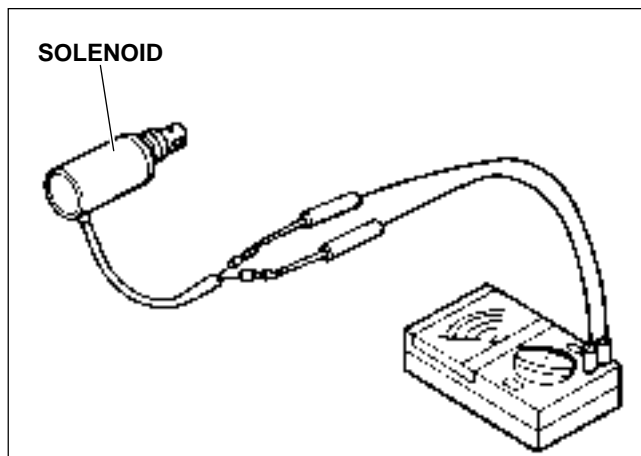
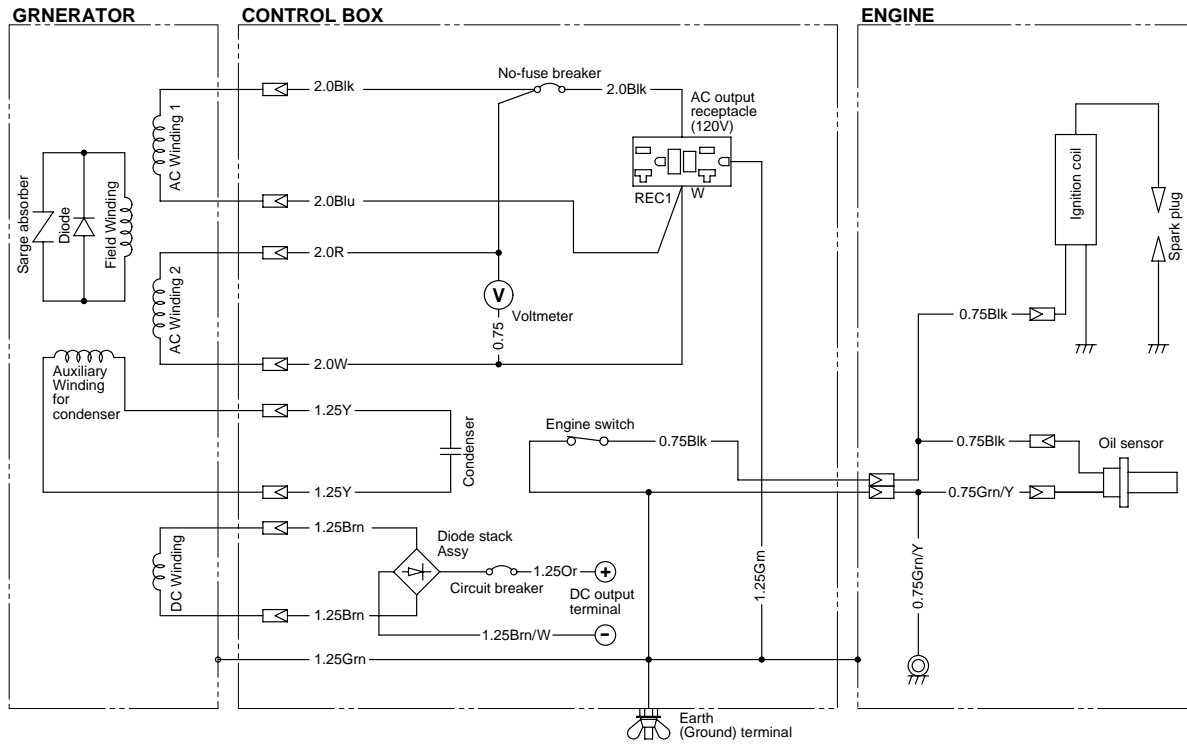

Fig. 11-17

# 12. WIRING DIAGRAM

\* RGV2800 : U.S.A., 60Hz-120V TYPE [NEMA RECEPTACLE]



\* RGV4100 : U.S.A., 60Hz-120V/240V TYPE [NEMA RECEPTACLE]

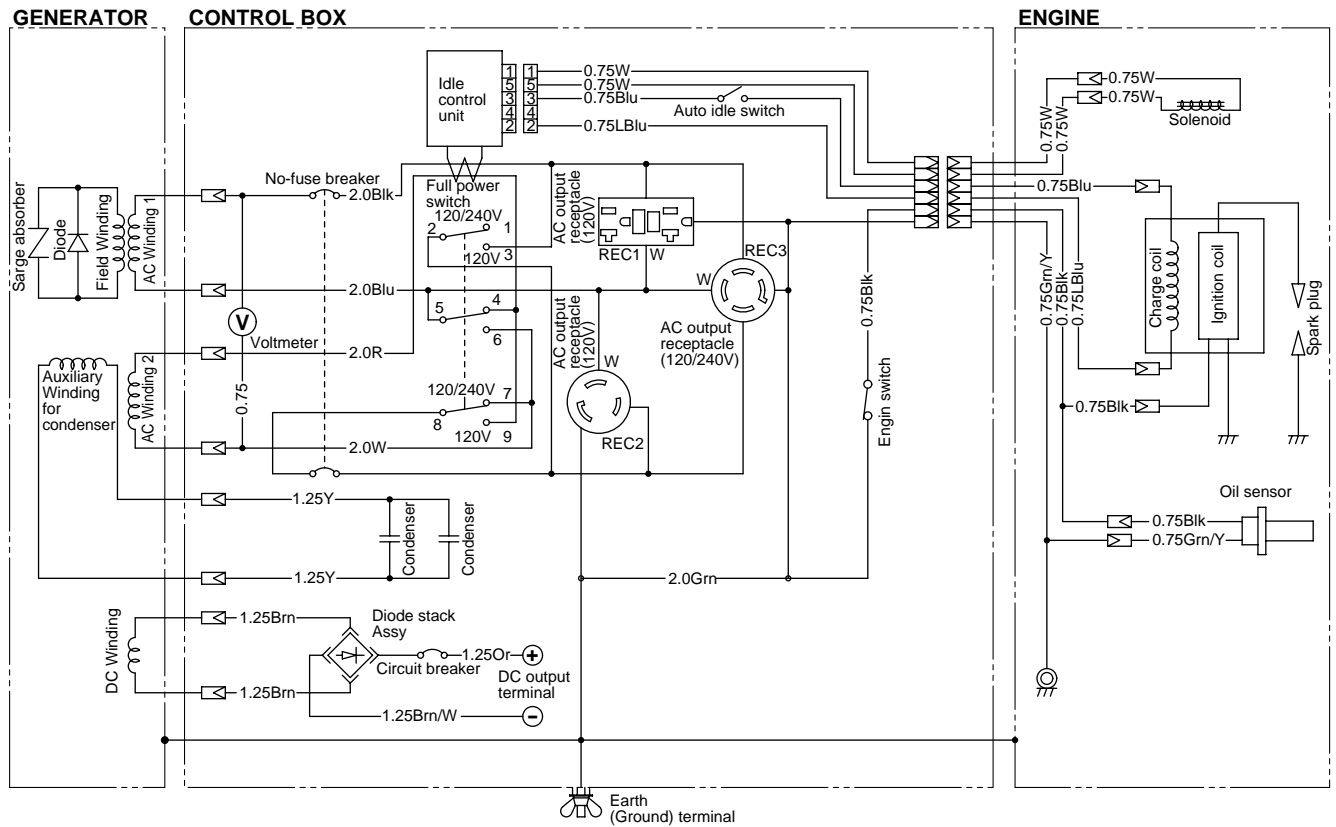



**\*RGV6100 : U.S.A., 50Hz-120V/240V TYPE [NEMA RECEPTACLE**

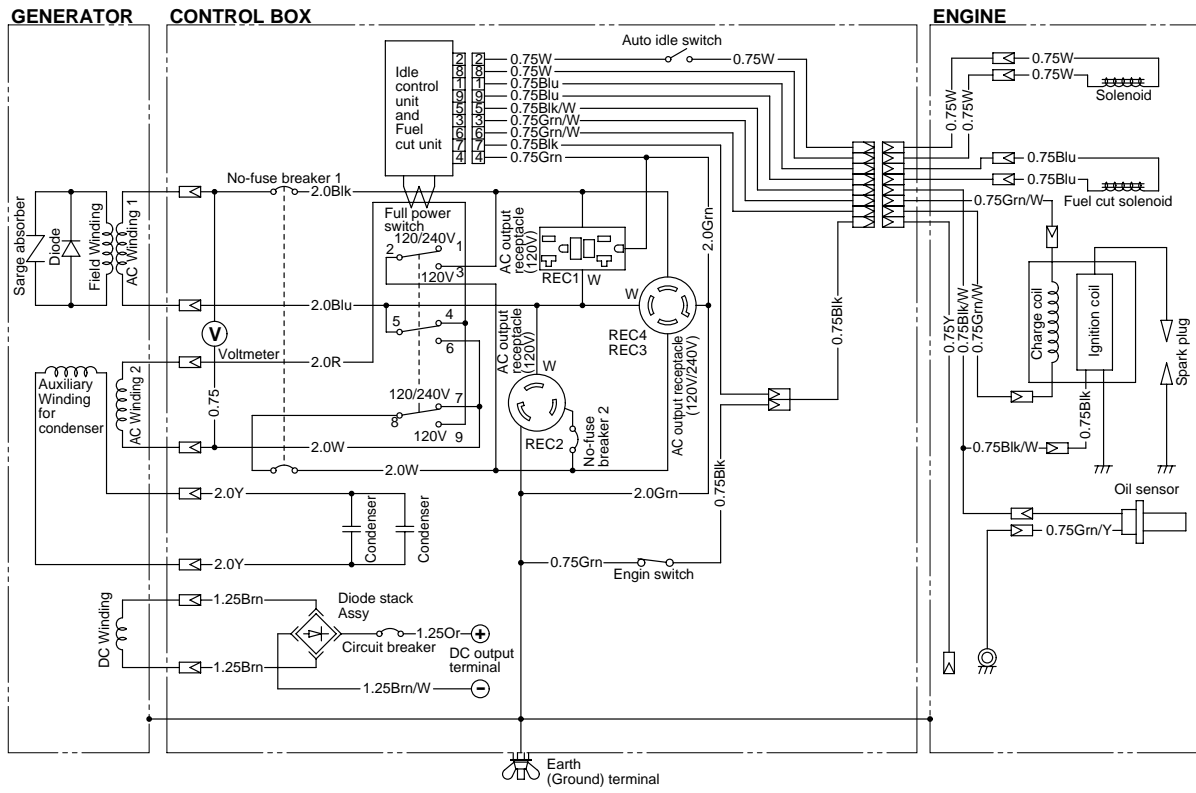

**\*RGV4100, 6100 : ELECTRIC STARTER TYPE**

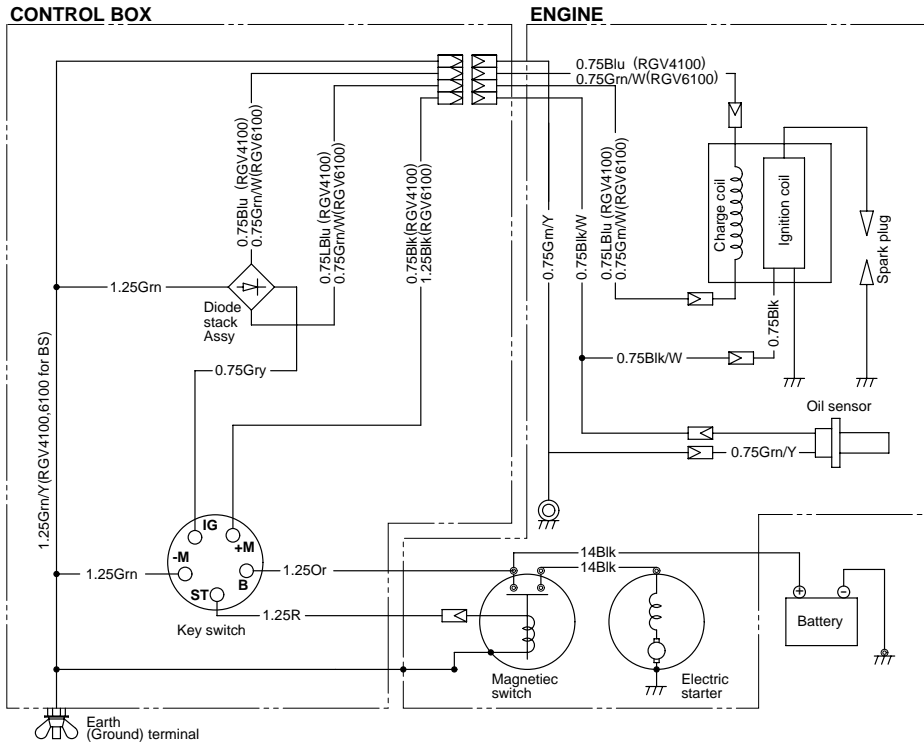

**Wiring color cord**

Blk	: Black	Brn/W	: Brown/White	R	: Red
Blk/W	: Black/White	Grn	: Green	W	: White
Blu	: Blue	Grn/W	: Green/White	Y	: Yellow
LBlu	: Light blue	Org	: Orange		
Brn	: Brown	Gry	: Gray		

# **Robin America, Inc.**

940 Lively Blvd. • Wood Dale, IL 60191 • Phone: 630-350-8200 • Fax: 630-350-8212  
e-mail: [sales@robinamerica.com](mailto:sales@robinamerica.com) • [www.robinamerica.com](http://www.robinamerica.com)

PRINTED IN THE USA