

Mikasa Robin Engine

EC 08GH

PARTS LIST

Parts List of EC 08GH ENGINE
For Mikasa products.

MODEL

MT-60H,60H2 / MTR-35W



MIKASA SANGYO CO.,LTD.

96-9-300A

805-00904

PARTS REMARK INDEX

How to read the marks and remarks used in this parts book.

Section 1 : Explanation of Code Use In "MRK" Column

OO : Interchangeable between the new part and the old one.

XX : Not Interchangeable between new and old.

OX : New part is usable for the old machine but the old part is not usable for the new machine.

XO : The old part is usable for the new machine but the new part is not usable for the old machine.

Note : In case of the lack of interchangeability between the new part and old part, a new part may be used by replacing all other parts found in the assembly. In this case, refer to section 2 for instruction on identifying other parts involved in a new assembly.

AD : Newly established(added)

DC : Suspended(discontinued)

NC : Part number changed

QC : Quantity used has been changed

NS : Not supplied individually but supplied in an assembly or a group.

AS : Special part designed to allow interchangeability between new and old part.

CR : Correction

Section 2 : Items Found In "Remark" Column

Serial Numbers — Where indicated, this indicates a serial number range (inclusive) where a particular part is used.

Model Number — Where indicated, this shows that the corresponding part is utilized only with this specific model number or model number variant.

or * : All parts with the same number following # or * belong to the same assembly. this part cannot be interchanged individually with any other assemblies to replace an old part (indicated by #), with a new part(indicated by *), then all other parts of that assembly must be replaced with new ones.

Note : If more than one of the same reference number is listed, the last one listed indicates newest(or latest)part available.

Section 3: Example

REF NO.	PART NO.	PART NAME	QTY	MRK	REMARKS
457(1)	5122-09230	Hinge Metal, Upper/24g	1		-1070 #3 (5)
457(2)	5072-09420	Hinge Metal, Upper M16	1	OX(3)	U1071-(6)*3(7)

(1) Old part

(2) New part

(3) New part usable with old machine, but old part not usable with new machine (reference section 1).

(4) Old part number is used through this machine serial number.

(5) Old part, used in an assembly with other parts marked with #3. To use this part on a new machine, all other parts in this assembly must be replaced with old ones.

(6) New part put into use starting with this serial number and is still current.

(7) New part used in an assembly with other parts marked *3, to use this part as a replacement for an old part, all other *3 marked parts must be changed at the same time.

Section 4: Items Found In "MK2" Column

(only for suspended products)

! OO ("OO" is shown in figure) : The part shown in lower line is supplied.

! SD : Not available due to termination of production.

! NS : Not supplied individually, but supplied in an assembly or a group.

! PD : Supplied as unit product.

SS : Not available after stock run out.

(The contents of this parts catalog are subject to change without notice.)

1. CRANKCASE AND CYLINDER

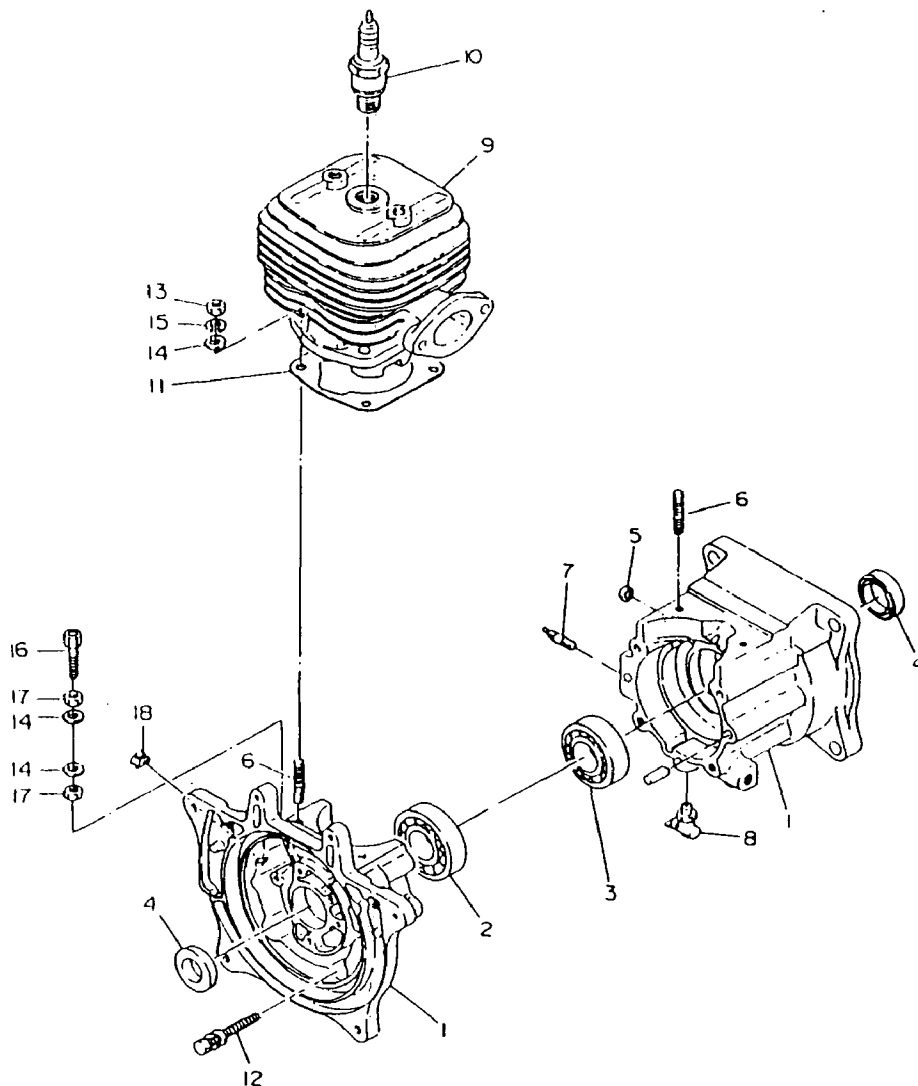

1996/2/23

**** 8 H J ****

REF NO.	PART NO.	PART NAME	Q' TY	MRK	MK2	REMARKS
1	580-10360-00	CRANKCASE COMPL.	1			INCL.2-7
2	060-02000-20	BALL BEARING 6204C3	1			
3	060-02000-10	BALL BEARING 6004C3	1			
4	044-02000-20	OIL SEAL	2			
5	044-00600-10	OIL SEAL	1			
6	010-50649-70	STUD	4			
7	010-50600-50	STUD	1			
8	064-31099-80	DRAIN COCK	1			
9	580-15014-00	CYLINDER CP	1			
10	065-01497-30	SPARK PLUG	1			B6HS
11	580-15018-00	GASKET, CYLINDER	1			
12	001-14064-50	BOLT ASS'Y	4			
13	002-18060-00	NUT	4			
14	003-10060-00	WASHER	6			
15	003-20060-00	SPRING WASHER	4			
16	014-90699-81	ADJUSTING SCREW	1		!014-	
17	002-27060-00	NUT	2			
18	024-10299-90	GROMMET	1		SS!EC	

2. CRANKSHAFT AND PISTON

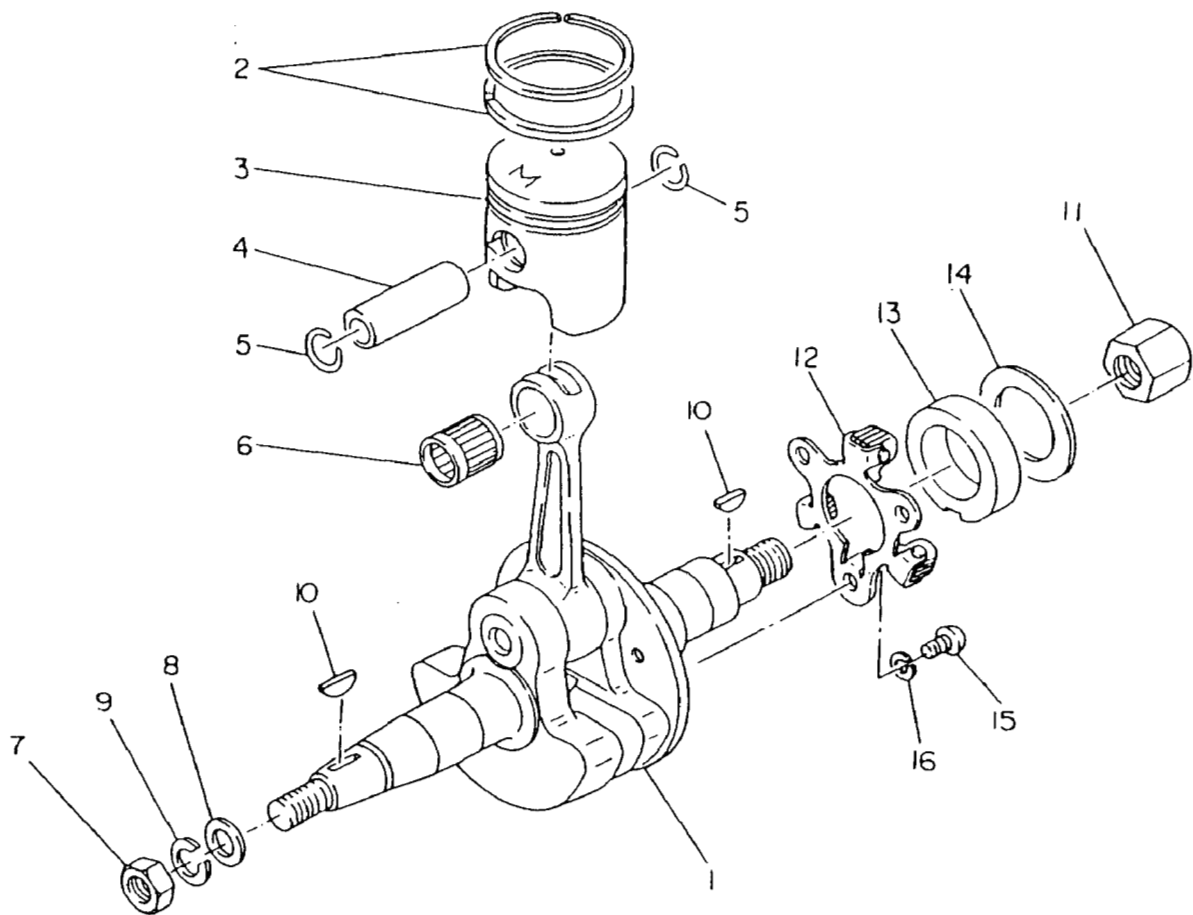

1996/2/23

**** 8 H K ****

REF NO.	PART NO.	PART NAME	Q' TY	MRK	MK2	REMARKS
1	580-20240-00	CRANKSHAFT CP	1			
2	580-25005-00	PISTON RING	2		!!580	
3	580-25006-00	PISTON	1			
4	580-25007-00	PISTON PIN	1			
5	056-51199-90	CLIP	2			
6	061-01200-10	NEEDLE BEARING	1			
7	002-18100-00	NUT	1			
8	003-10100-00	WASHER	1			
9	003-20100-00	SPRING WASHER	1			
10	005-32042-01	WOODRUFF KEY	2			
11	017-31200-10	LOCK NUT	1			
12	129-41703-22	GOVERNOR PLATE UNIT	1			
13	551-45001-00	GOVERNOR SLEEVE	1			
14	023-02300-20	SPACER	1			
15	004-31050-80	SCREW (PAN HEAD)	3			
16	003-20050-00	SPRING WASHER	3			

3. GOVERNOR

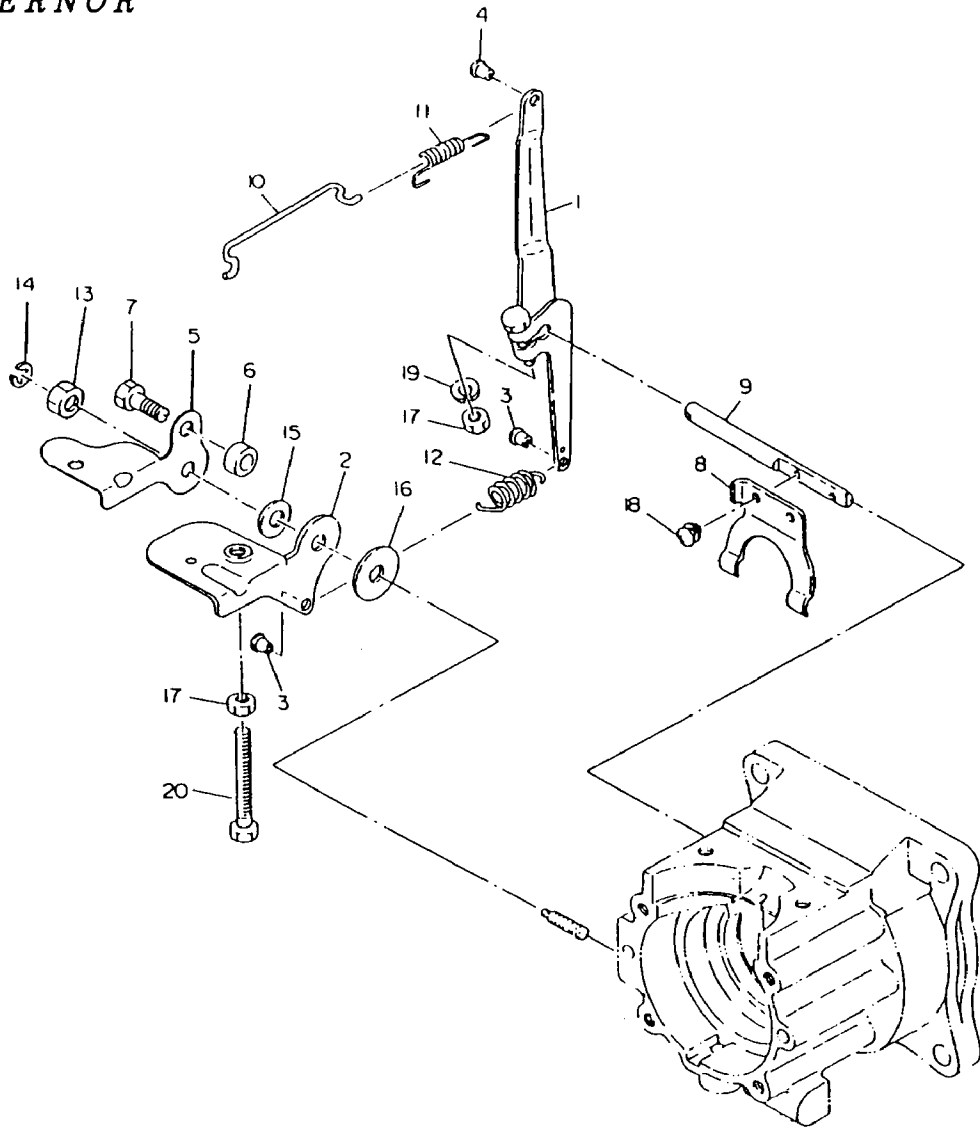

1996/2/23

** 8 H L **

REF NO.	PART NO.	PART NAME	Q' TY	MRK	MK2	REMARKS
1	580-40050-00	GOVERNOR LEVER CP	1			
2	580-45008-00	CONTROL LEVER	1			
3	580-45009-00	BUSH	2			
4	580-60830-60	BUSH, NYLON	1			
5	580-45006-00	STOP PLATE	1			
6	023-00600-90	SPACER	1			
7	620-25004-00	BOLT	1			
8	129-42101-13	GOVERNOR YOKE	1			
9	129-42201-03	GOVERNOR SHAFT	1			
10	105-42701-11	GOVERNOR ROD	1			
11	106-42801-11	ROD SPRING	1			!106-
12	129-42501-11	GOVERNOR SPRING	1			
13	017-00699-60	U NUT	1			#EC08
14	129-45001-03	CLIP	1			
15	020-00700-10	WASHER	1			
16	021-70600-20	FRICTION WASHER	1			
17	002-17060-00	NUT	2			
18	014-00399-80	SCREW AY	2			
19	003-20060-00	SPRING WASHER	1			
20	001-65064-00	BOLT	1			

4. MUFFLER

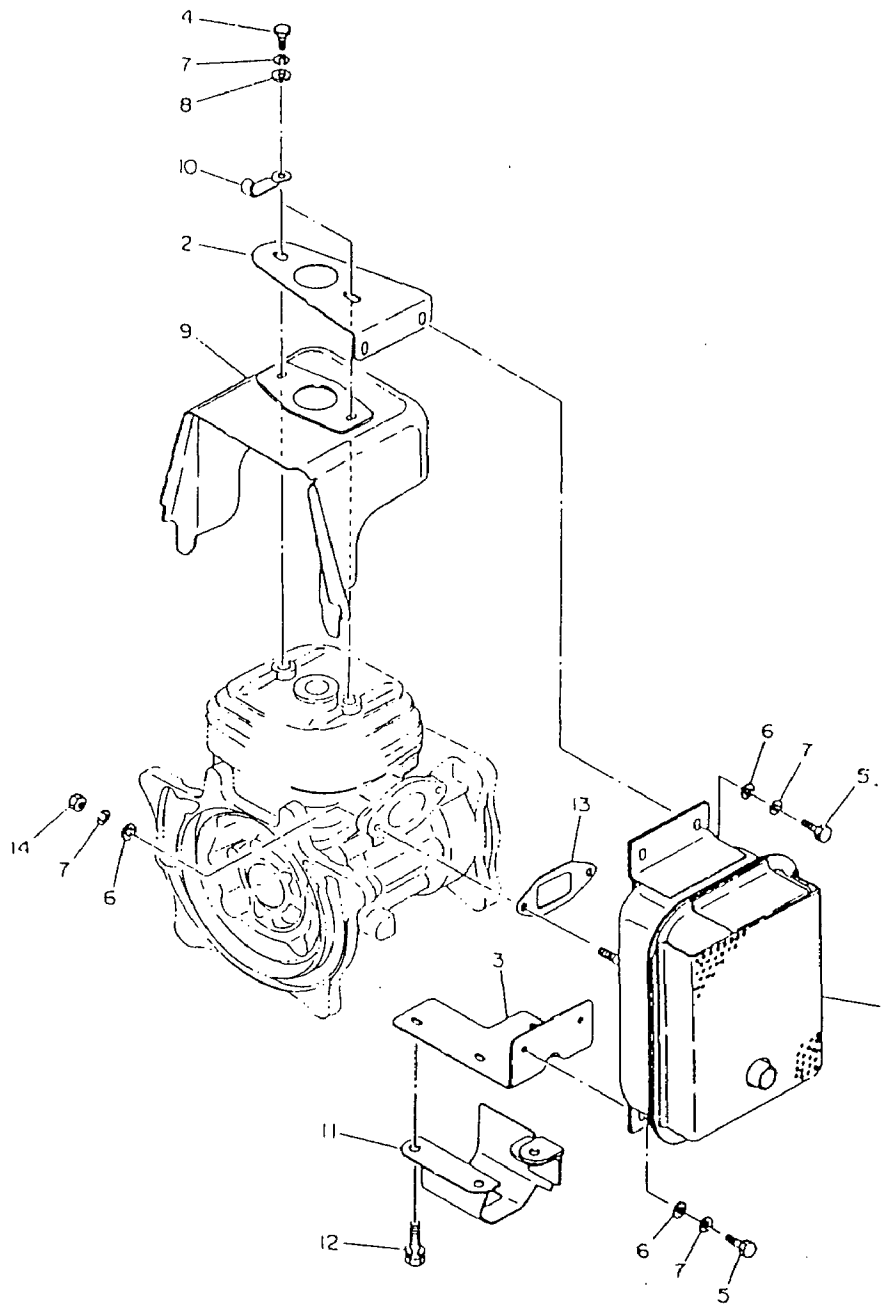

1996/8/28

**** 8 HM ****

REF NO.	PART NO.	PART NAME	Q' TY	MRK	MRK2	REMARKS
1	580-30320-00	MUFFLER UN	1			FOR MT-60H/H2
1	580-30510-00	MUFFLER UN MTR-35W	1			FOR MT-35W
2	580-30330-00	MUFFLER BRACKET A	1			
3	580-30340-00	MUFFLER BRACKET B	1			
4	001-67062-00	BOLT (CYLINDER)	2			
5	001-67061-60	BOLT (MUFFLER)	4			
6	003-10060-00	WASHER	6			
7	003-20060-00	SPRING WASHER	8			
8	003-12060-00	WASHER	2			
9	580-50120-00	CYLINDER COVER	1			
10	056-60999-50	CLAMP	1		#EC08	
11	580-90110-00	PROTECTOR COMPL.	1		!!580	
12	001-13081-80	BOLT AND WASHER ASSY	3			
13	129-35004-03	GASKET (MUFFLER)	1			
14	017-00699-60	U NUT	2		#EC08	

5-1 CARBURETOR AND AIR CLEANER (For MT-60H)

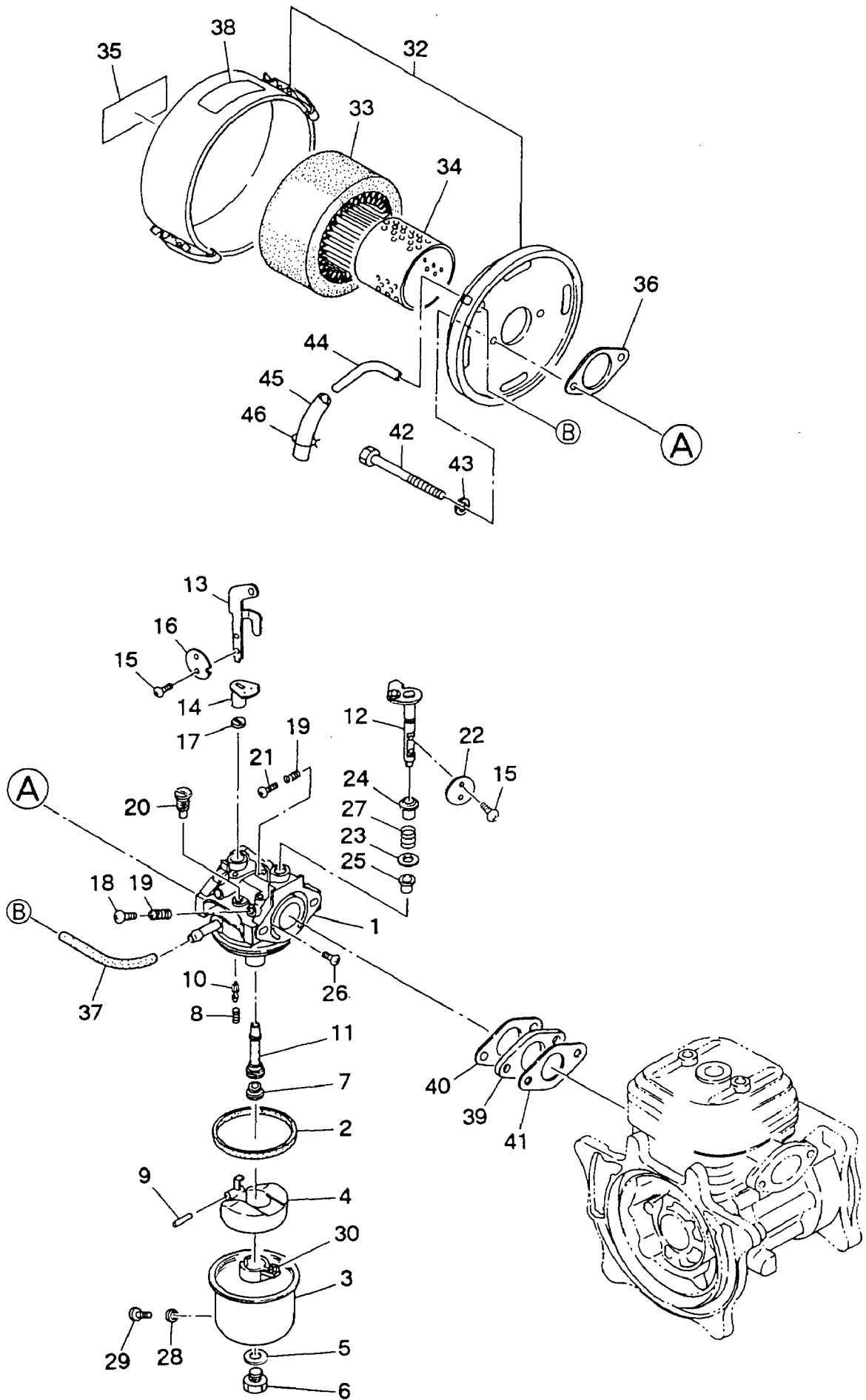

5-1. CARBURETOR AND AIR CLEANER (MT-60H)

8HN

REF NO.	PART NO.	PART NAME	Q' TY	MRK	MK2	REMARKS
1	580-60830-02	CARBURETOR AY	1		!580-	INCL.2-29 *1
1	580-60830-03	CARBURETOR AY	1	00		INCL.2-30 *2
2	580-60833-40	PACKING	1			
3	580-60830-10	FLOAT BODY ASSY	1			
4	580-60833-50	FLOAT	1			
5	580-60833-30	PACKING	1			
6	580-60830-20	BOLT	1			
7	530-60093-20	MAIN JET #72.5	1			
8	580-60832-40	SPRING	1			
9	541-60020-50	PIN	1			
10	580-60832-50	NEEDLE	1			#1
10	580-60834-00	NEEDLE	1	XX		*1
11	580-60832-60	MAIN NOZZLE	1			
12	580-60830-30	THROTTLE SHAFT ASSY	1			
13	580-60830-40	CHOKE LEVER	1			
14	580-60830-50	RING	1			
15	580-60831-60	SCREW	4			
16	580-60833-10	CHOKE VALVE	1			
17	580-60830-60	BUSH,NYLON	1			
18	541-60021-50	PILOT SCREW	1			
19	804-60012-30	SPRING	2			
20	560-60030-20	PILOT JET	1			
21	541-60022-30	SCREW	1			
22	580-60831-10	THROTTLE VALVE	1			
23	580-60832-30	PACKING	1			
24	580-60831-20	RING	1			
25	580-60832-10	SEAL	1			
26	580-60831-30	SCREW	1			
27	580-60831-40	SPRING	1			
28	580-60833-20	PACKING	1			
29	580-60831-50	SCREW	1			
30	580-60833-70	FLOAT STOPPER	1			*2
32	580-30350-01	AIR CLEANER ASSY	1		SS!58-	INCL.33-36
33	580-30350-50	ELEMENT	1		!NS!5	
34	580-30350-40	ELEMENT	1		!NS!5	
35	580-30190-20	LABEL,CLEANER	1		!128-	
36	580-30350-30	PACKING	1		!236-	
37	085-10099-81	RUBBER PIPE	1			
38	073-64399-80	LABEL	1			
39	580-35012-00	INSULATOR	1			
40	236-35903-03	GASKET 2 (INSULATOR)	1		!237-	
41	106-35001-03	GASKET (INSULATOR)	1			
42	001-13067-50	BOLT	2		!001-	
43	003-20060-00	SPRING WASHER	2			
44	510-65011-00	PIPE	1			
45	085-10899-70	TUBE	1			
46	056-50999-90	CLIP	1			

5-2 CARBURETOR AND AIR CLEANER (For MT-60H2/MTR-35W)

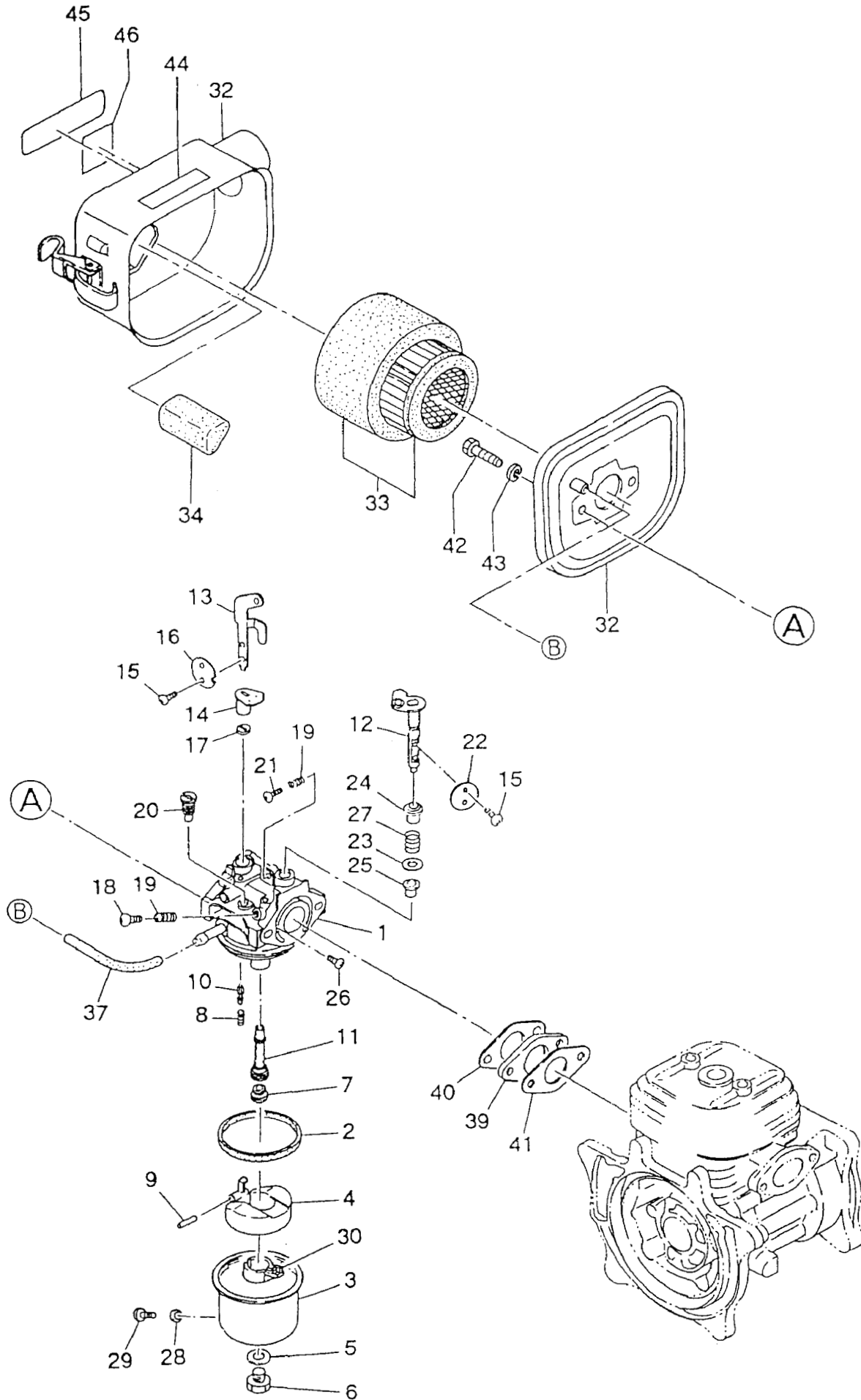

5-2. CARBURETOR & AIR CLEANER (MT-60H2/MTR-35W)

8PF

REF NO.	PART NO.	PART NAME	Q' TY	MRK	MK2	REMARKS
1	580-61110-00	CARBURETOR AY	1			
2	580-60833-40	PACKING	1			
3	580-60830-10	FLOAT BODY ASSY	1			
4	580-60833-50	FLOAT	1			
5	580-60833-30	PACKING	1			
6	580-60830-20	BOLT	1			
7	129-62401-08	MAIN JET #77.5	1			
8	580-60832-40	SPRING	1		!236-	
9	541-60020-50	PIN	1			
10	580-60834-00	NEEDLE	1			
11	580-60832-60	MAIN NOZZLE	1			
12	580-60830-30	THROTTLE SHAFT ASSY	1			
13	580-60830-40	CHOKE LEVER	1			
14	580-60830-50	RING	1		!234-	
15	580-60831-60	SCREW	4			
16	580-60833-10	CHOKE VALVE	1			
17	580-60830-60	BUSH, NYLON	1			
18	541-60021-50	PILOT SCREW	1			
19	804-60012-30	SPRING	2			
20	560-60030-20	PILOT JET	1			
21	541-60022-30	SCREW	1			
22	580-60831-10	THROTTLE VALVE	1			
23	580-60832-30	PACKING	1			
24	580-60831-20	RING	1			
25	580-60832-10	SEAL	1			
26	580-60831-30	SCREW	1			
27	580-60831-40	SPRING	1			
28	580-60833-20	PACKING	1			
29	580-60831-50	SCREW	1			
30	580-60833-70	FLOAT STOPPER	1			
32	106-32731-10	AIR CLEANER AY	1			INCL. 33, 34
33	157-36201-01	ELEMENT SET	1			
34	161-32610-08	ELEMENT	1			
37	085-10099-81	RUBBER PIPE	1			
39	580-35012-00	INSULATOR	1			
40	236-35903-03	GASKET 2 (INSULATOR)	1		!237-	
41	106-35001-03	GASKET (INSULATOR)	1			
42	001-13067-50	BOLT	2		!001-	
43	003-20060-00	SPRING WASHER	2			
44	073-20019-30	LABEL (CHOKE)	1			
45	107-32733-08	LABEL	1			
46	9202-03980	DECAL, ELEMENT SET	1			

6 RECOIL STARTER AND BLOWER HOUSING

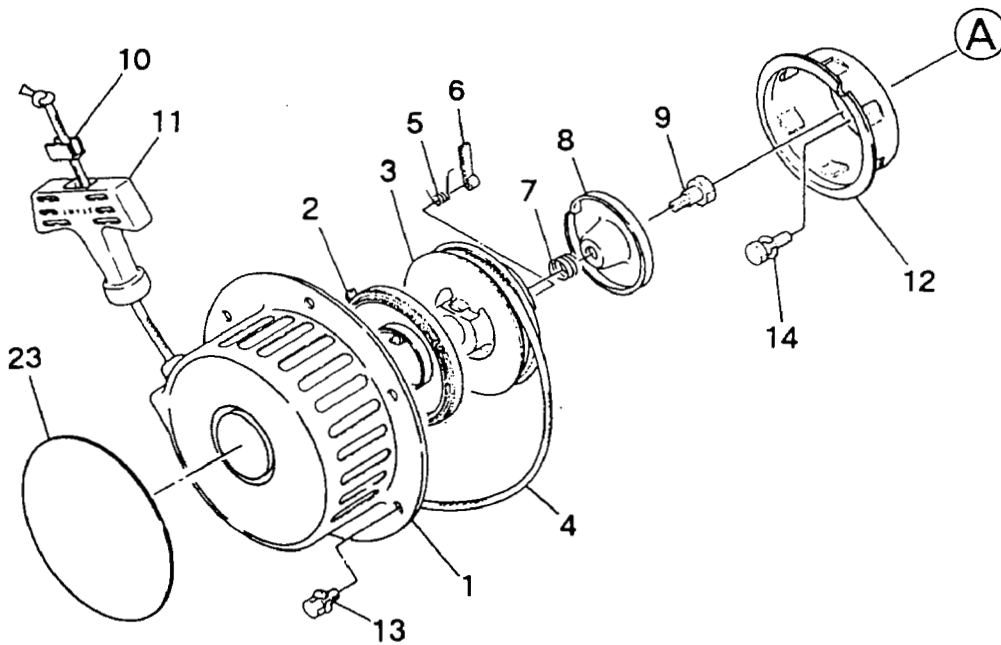
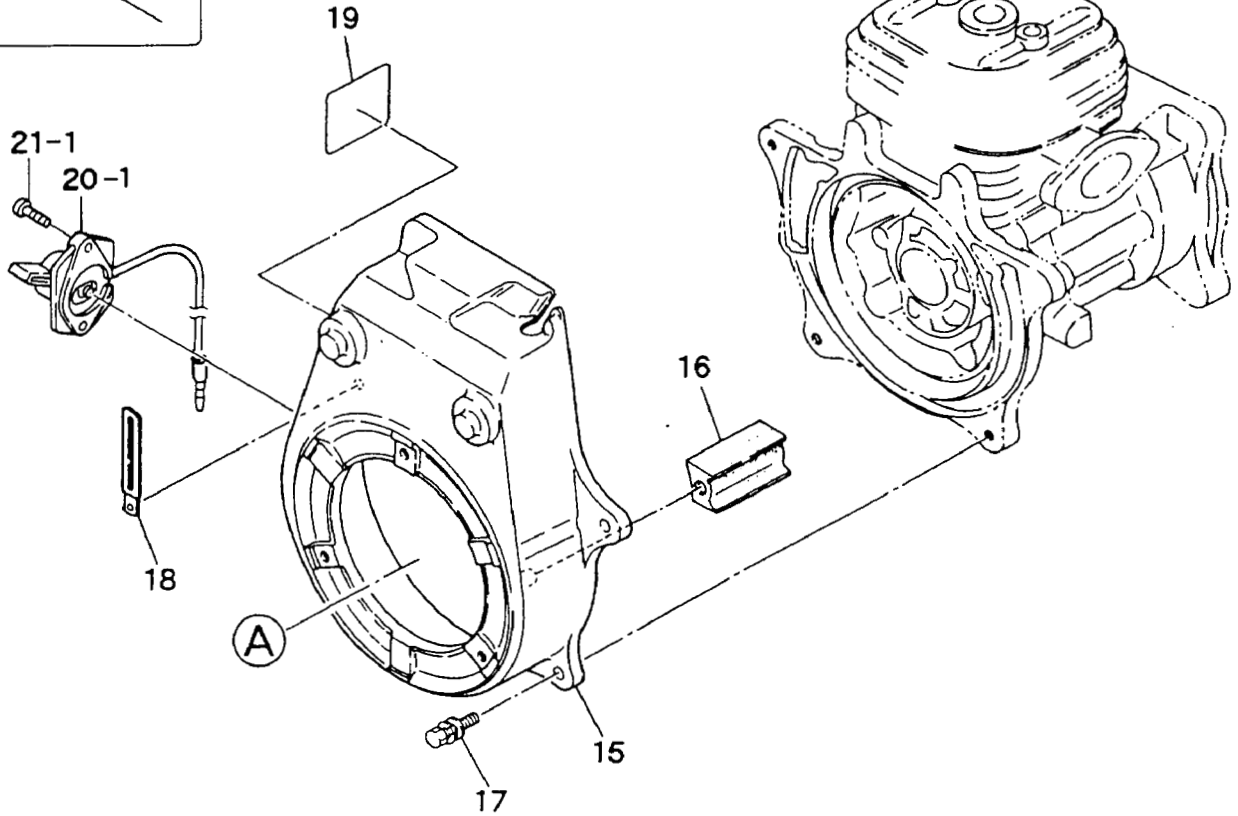
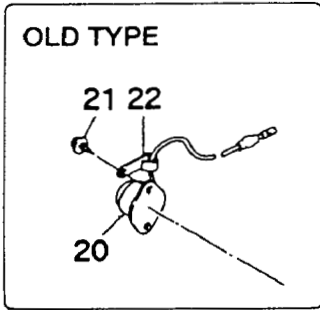

7. MAGNETO

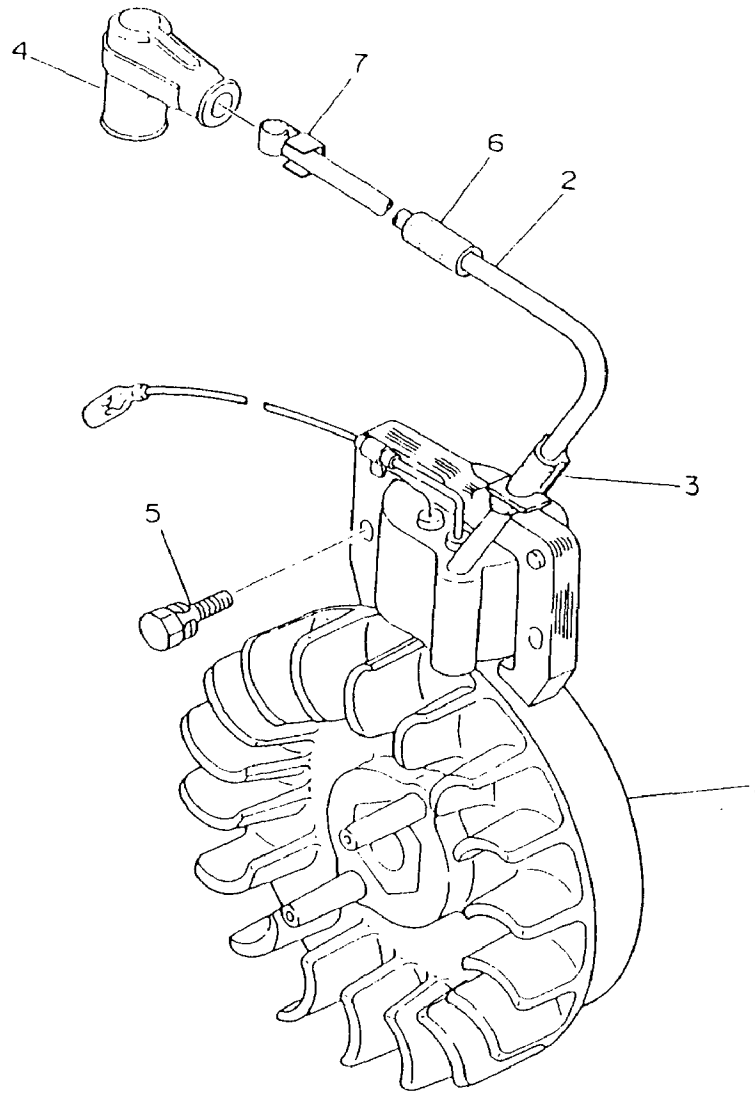

1996/2/23

**** 8 H O ****

REF NO.	PART NO.	PART NAME	Q' TY	MRK	MK2	REMARKS
1	580-70050-01	MAGNETO CP	1			INCL.2
1	580-70070-00	MAGNETO CP	1	00		
2	580-70020-20	IGNITION COIL	1		!580-	
2	580-70070-20	IGNITION COIL	1	00		
3	024-10699-80	GROMMET	1		#EC05	
4	065-50001-40	SPARK PLUG CAP	1			
5	001-11052-50	BOLT AND WASHER ASSY	2			
6	085-10299-60	VINYL PIPE	1			
7	065-50001-00	SPARK PLUG CAP	1		SS!06	

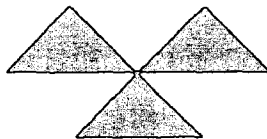

MIKASA SANGYO CO.,LTD.

TOKYO, JAPAN



MULTIQUIP INC.
POST OFFICE BOX 6254
CARSON, CALIFORNIA 90749
(310) 537-3700
800/421-1244 NATIONWIDE
FAX: (310) 537-3927