

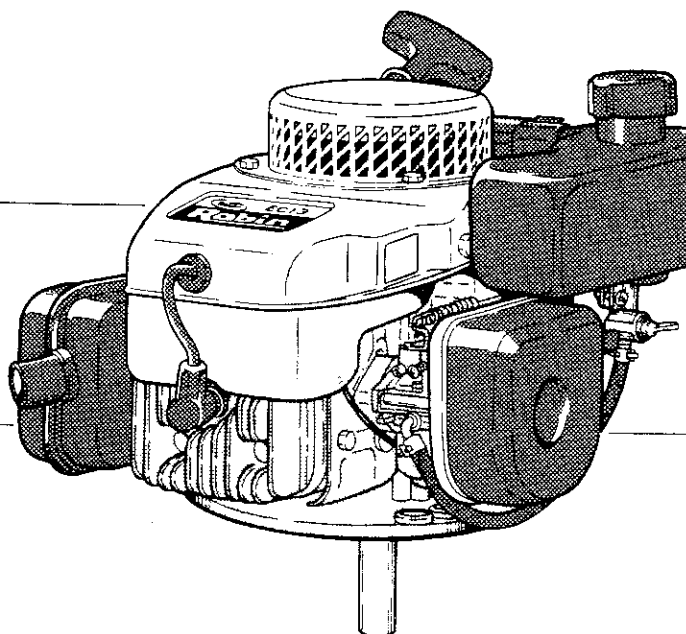

MODEL

EC13V

INSTRUCTIONS for USE
FOR EMISSION CERTIFIED ENGINE



ISSUE EMD-EU1142

1ZZ9020021

Robin Engines

NOTICE

The **FEDERAL EMISSION COMPONENT DEFECT WARRANTY** stated in the beginning of this manual are only applicable to the engines sold and used in the U.S.A.

To the engines exported to and used in the countries other than the U.S.A., warranty service shall be performed by the distributor in each country in accordance with the standard Robin engine warranty policy as applicable.



WARNING:



The engine exhaust from this product contains chemicals known to the State of California to cause cancer, birth defects or other reproductive harm.

FEDERAL EMISSION COMPONENT DEFECT WARRANTY

EMISSION COMPONENT DEFECT WARRANTY COVERAGE – This emission warranty is applicable in all States in the U.S.A., except the State of California.

Fuji Heavy Industries Ltd. and Robin America Inc., Wood Dale, Illinois, (herein "ROBIN AMERICA") warrants to the initial retail purchaser and each subsequent owner, that this utility equipment engine (herein "engine") has been designed, built, and equipped to conform at the time of initial sale to all applicable regulations of the U. S. Environmental Protection Agency (EPA), and that the engine is free of defects in materials and workmanship which would cause this engine to fail to conform with EPA regulations during its warranty period.

For the components listed under PARTS COVERED, the dealer or service center authorized by ROBIN AMERICA will, at no cost to you, make the necessary diagnosis, repair, or replacement necessary to ensure that the engine complies with applicable U. S. EPA regulations.

EMISSION COMPONENT DEFECT WARRANTY PERIOD

The warranty period for this engine begins on the date of sale to the initial purchaser and continues for a period of 2 years.

PARTS COVERED

Listed below are the parts covered by the Emission Component Defect Warranty.

Some of the parts listed below may require scheduled maintenance and are warranted up to the first scheduled replacement point for that part.

- | | |
|------------------------------------|--|
| 1) Fuel Metering System | 3) Ignition System |
| (i) Carburetor and internal parts | (i) Spark plug |
| (ii) Choke System | (ii) Magneto |
| (iii) Fuel strainer, if applicable | 4) Exhaust pipe, if applicable |
| 2) Air Induction System | 5) Miscellaneous Items Used in Above Systems |
| (i) Air filter element | (i) Fuel hoses, clamps and sealing gaskets |
| (ii) Intake pipe, if applicable | |

OBTAINING WARRANTY SERVICE

To obtain warranty service, take your engine to the nearest authorized Robin America distributor or dealer. Bring your sales receipts indicating date of purchase for this engine. The dealer or service center authorized by ROBIN AMERICA, will perform the necessary repairs or adjustments within a reasonable amount of time and furnish you with a copy of the repair order.

All parts and accessories replaced under this warranty become the property of ROBIN AMERICA.

WHAT IS NOT COVERED

- * Conditions resulting from tampering, misuse, improper adjustment (unless they were made by the dealer or service center authorized by ROBIN AMERICA during a warranty repair), alteration, accident, failure to use the recommended fuel and oil, or not performing required maintenance services.
- * The replacement parts used for required maintenance services.
- * Consequential damages such as loss of time, inconvenience, loss of use of the engine of equipment, etc.

- * Diagnosis and inspection charges that do not result in warranty-eligible service being performed.
- * Any non-authorized replacement part, or malfunction of authorized parts due to use of non-authorized parts.

OWNER'S WARRANTY RESPONSIBILITIES

As the engine owner, you are responsible for the performance of the required maintenance listed in your owner's manual. ROBIN AMERICA recommends that you retain all receipts covering maintenance on your engine, but Robin America can not deny warranty solely for the lack of receipts or for your failure to ensure the performance of all scheduled maintenance.

As the engine owner, you should however be aware that the ROBIN AMERICA may deny your warranty coverage if your engine or a part has failed due to abuse, neglect, improper maintenance or unapproved modifications.

You are responsible for presenting your engine to the nearest dealer or service center authorized by ROBIN AMERICA when a problem exists.

If you have any questions regarding your warranty rights and responsibilities, you should contact the Robin America Inc. Customer service department at 1-630-350-8200 for the information.

THINGS YOU SHOULD KNOW ABOUT THE EMISSION CONTROL SYSTEM WARRANTY MAINTENANCE AND REPAIRS

You are responsible for the proper use and maintenance of the engine. You should keep all receipts and maintenance records covering the performance of regular maintenance in the event questions arise. These receipts and maintenance records should be transferred to each subsequent owner of the engine. ROBIN AMERICA reserves the rights to deny warranty coverage if the engine has not been properly maintained. Warranty claims will not be denied, however, solely because of the lack of required maintenance or failure to keep maintenance records.

MAINTENANCE, REPLACEMENT OR REPAIR OF EMISSION CONTROL DEVICES AND SYSTEMS MAY BE PERFORMED BY ANY REPAIR ESTABLISHMENT OR INDIVIDUAL ; HOWEVER, WARRANTY REPAIRS MUST BE PERFORMED BY A DEALER OR SERVICE CENTER AUTHORIZED BY ROBIN AMERICA. THE USE OF PARTS THAT ARE NOT EQUIVALENT IN PERFORMANCE AND DURABILITY TO AUTHORIZED PARTS MAY IMPAIR THE EFFECTIVENESS OF THE EMISSION CONTROL SYSTEM AND MAY HAVE A BEARING ON THE OUTCOME OF A WARRANTY CLAIM.

If other than the parts authorized by ROBIN AMERICA are used for maintenance replacements or for the repair of components affecting emission control, you should assure yourself that such parts are warranted by their manufacturer to be equivalent to the parts authorized by ROBIN AMERICA in their performance and durability.

HOW TO MAKE CLAIM

All repairs qualifying under this limited warranty must be performed by a dealer or service center authorized by ROBIN AMERICA. In the event that any emission-related part is found to be defective during the warranty period, you shall notify ROBIN AMERICA customer service department at 1-630-350-8200 and you will be given the appropriate warranty service facilities where the warranty repair can be performed.

FOREWORD

Thank you for purchasing a Robin product.

Read this manual carefully to learn how to operate and maintain your engine correctly and safely.

Due to constant efforts to improve our products, certain procedures and specifications are subject to change without notice.

When ordering spare parts, always give us the MODEL, SPECIFICATION NUMBER and SERIAL NUMBER of your engine.

Check the specification number on your engine and fill in the following blanks for your convenience.









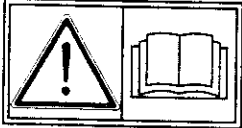
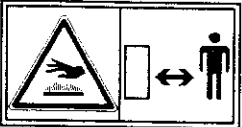
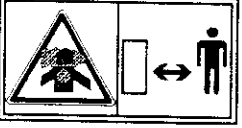

SPEC NO.

E	C								
---	---	--	--	--	--	--	--	--	--

CONTENTS

1. SAFETY PRECAUTIONS	1
2. COMPONENTS	3
3. PRE-OPERATION CHECKS	4
4. OPERATING THE ENGINE	5
5. MAINTENANCE	7
6. PREPARATION FOR LONG STORAGE	10
7. SPECIFICATIONS	11

SYMBOLS

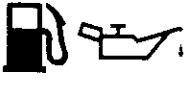
	<p><i>Read the owner's manual.</i></p>		
	<p><i>Stay clear of the hot surface.</i></p>		
	<p><i>Exhaust gas is poisonous. Do not operate in an unventilated area.</i></p>		
	<p><i>Stop the engine before refueling.</i></p>		
	<p><i>Fire, open flame and smoking prohibited.</i></p>		
	<p><i>On (Run)</i></p>		<p><i>Plus ; Positive polarity</i></p>
	<p><i>Off (Stop)</i></p>		<p><i>Battery</i></p>
	<p><i>Engine oil</i></p>		<p><i>Engine start (Electric start)</i></p>
	<p><i>Choke</i></p>		
 <p>25~50:1</p>	<p><i>Maxing ratio of gasoline and oil for 2 cycle fuel.</i></p>		

1. SAFETY PRECAUTIONS

EXHAUST PRECAUTIONS

- Do not run the engine in an enclosed area or in a poorly ventilated area such as tunnel, cave, etc.
Exhaust gases contain carbon monoxide, an odorless and deadly poison.

FIRE PREVENTION

A fire or explosion can occur resulting in personal injury if the following instructions are not followed:

1. Do not fill gasoline tank while engine is running. Refuel only after engine has cooled down.
2. Do not operate the engine when an odor of gasoline is present or other explosive conditions exists.
3. If gasoline is spilled, wipe off completely before starting the engine.
4. Do not smoke or allow open flames or spark while refueling, servicing fuel system, draining fuel and adjusting carburetor.
5. Refuel outdoors preferably, or only in well ventilated areas.
6. Do not operate engine without a muffler. Inspect muffler periodically and replace if necessary.
7. Keep clean the muffler area to prevent grass, dirt and combustible material from accumulating.
8. Do not use this engine on any forest covered, bush covered or grass covered unimproved land.
9. Except for adjustment, do not operate the engine if air cleaner or cover directly over the carburetor air intake is removed.
10. When transporting engine or equipment, the fuel cock must be shut off.

AVOID PERSONAL INJURY

- Do not run engine at excessive speeds.
Operating an engine at excessive speeds increases the danger of personal injury.
- 1. Do not change governor setting.
Do not tamper with governor springs, governor links or other parts which may increase the engine speed.
- 2. Do not tamper with the engine speed selected by the original equipment manufacturer.
- 3. Dirt and grass clippings or other debris in cooling fins or governor parts can affect engine speed.
- Do not touch hot mufflers, cylinders or fins as contact may cause burns.
- Do not touch high-tension cord or spark plug cap while engine is running.
- Always keep hands and feet clear of moving or rotating parts.
- To prevent hand or arm injury, always pull starter rope rapidly to avoid kickback.
- To prevent accidental starting when servicing the engine or equipment, always remove the spark plug or wire from the spark plug.
- Do not strike flywheel with a hard object or metal tool as this may cause flywheel to shatter in operation, causing personal injury or property damage.

2. COMPONENTS

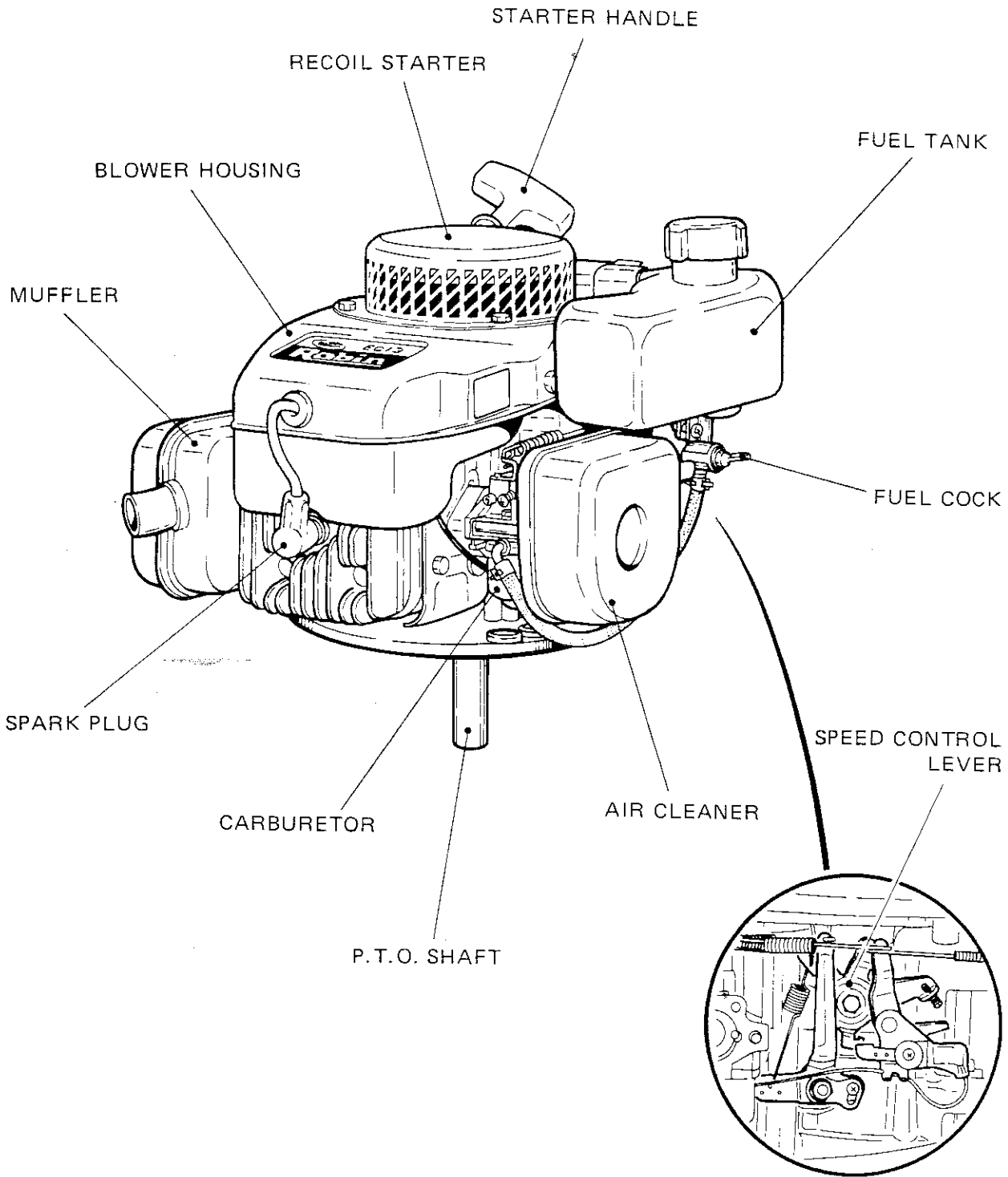

3. PRE-OPERATION CHECKS

FUEL

- The fuel tank capacity is approx. 2 liters.
- Use the mixture fuel prepared by mixing gasoline and exclusive 2-cycle oil at a ratio of 45 ~ 50:1, or the 2-cycle fuel now available on the market.

[CAUTION]

For break-in of a new engine, use mixture fuel of gasoline 20 ~ 25:1, 2-cycle engine oil, during first two hours of operation.

- Close fuel cock before replenishing fuel tank.
- Use fuel strainer provided at the fuel filler whenever adding fuel.
- Wipe off spilt fuel before starting engine.
Spilt fuel could cause a fire.

[CAUTION]

1. Never operate the engine with gasoline only. (Use the mixture fuel.)
2. Never replenish fuel to fuel tank while the engine is running or hot, since it is very dangerous. Stop the engine and close fuel cock without fail before supplying fuel.

TO INSTALL REMOTE CONTROL WIRE

This engine is designed to accept a remote control wire.

1. Use control wire which will fit into 2.5 mm (0.098 in.) dia. wire hole and 6 mm (0.236 in.) casing hole.
2. Assemble the control wire and casing to the engine through the control wire bracket and lock the casing by clamping the control wire bracket.
3. Loosen control wire lock screw and insert the control wire in a hole of speed control lever.
4. Place control lever in fully "STOP" position and tighten control wire lock screw.

4. OPERATING THE ENGINE

STARTING PROCEDURES

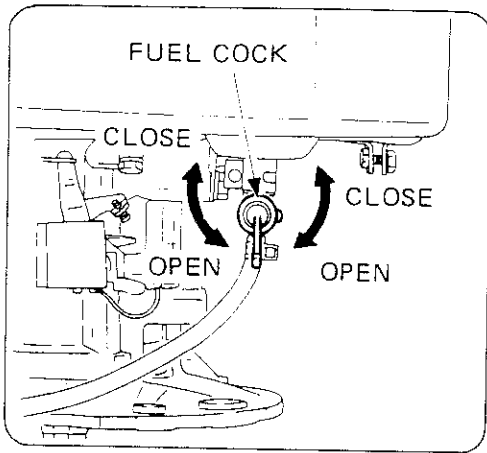

1. Open fuel cock.

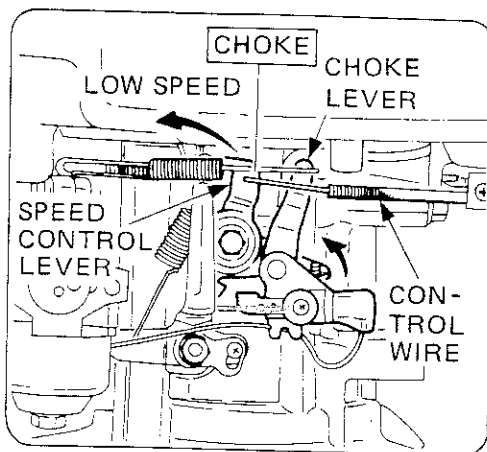

2. Close choke by speed control lever to "CHOKE" position.
If the engine is warm or the ambient temperature is high, open choke half-way or fully.

3. Pull starter handle quickly and forcibly.
Do not pull out the rope all the way.
After starting the engine, allow the starter handle to return to its original position while still holding the handle.
4. After starting the engine, gradually open choke and finally open it fully.
Do not open choke immediately when the engine is cold or the ambient temperature is low, because the engine may stop.

RUNNING

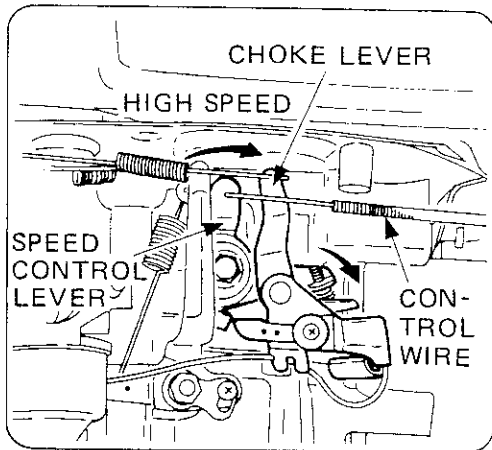

1. After engine starts, warm it up at slow speed without load for about 5 minutes.
2. Increase engine speed to the required value by moving control lever after warm-up.

NOTE: Whenever high speed operation is not required, slow engine down (idle), by means of speed control lever. This practice will result in fuel economy and increase engine life.

STOPPING

1. Slow down speed and allow the engine to run at idle speed for 2 or 3 minutes before stopping.
2. Move control lever fully to "STOP" position.
The control lever should fully contact the stop switch.

NOTE: Do not stop engine suddenly while running at high speed.

3. Close fuel cock.

STOPPING BY FUEL COCK (for long storage)

Close fuel cock and wait for a while until engine stops. Avoid leaving the engine for a long time without draining fuel, otherwise the passage of the carburetor may become clogged with impurities, and malfunctions may result.

5. MAINTENANCE

DAILY AND REGULAR CHECKS

DAILY CHECK

Make the following daily checks without fail before starting engine.

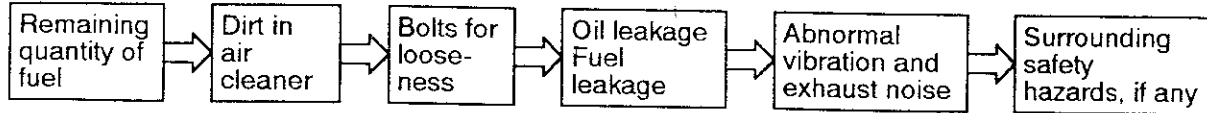

PERIODIC MAINTENANCE

Periodic maintenance is vital to safe and efficient operation of your engine.

Check the table below for periodic maintenance intervals.

It is also necessary for the user of this engine to conduct the maintenance and adjustments on the emission-related parts listed below to keep the emission control system effective.

The emission control system consists of the following parts:

- | | | |
|----------------------------------|--|------------------|
| (1)Carburetor and internal parts | (2)Choke system | (3)Fuel strainer |
| (4)Air cleaner elements | (5)Intake pipe | (6)Spark plug |
| (7)Magneto | (8)Fuel hoses, clamps, and sealing gaskets | |

The maintenance schedule indicated in the following table is based on the normal engine operation. Should the engine be operated in extremely dusty condition or in heavier loading condition, the maintenance intervals must be shortened depending on the contamination of oil, clogging of filter elements, wear of parts, and so on.

Items	Operating hours	every 8 hours (daily)	every 50 hours (weekly)	every 200 hours (monthly)	every 500 hours
Clean engine and check bolts and nuts		○			
Clean spark plug			○		
Clean air cleaner			○		
Clean fuel strainer				○	
Adjust spark plug gap				○	
Clean cylinder head (*1)					○
Clean cooling system			○ (100 hr)		
Clean carburetor (*1)					○
Overhaul (*1)					○
Clean fuel tank					○

*Note :1. As to the procedures for these items, please refer to the SERVICE MANUAL or consult your nearest Robin service dealer.

[CAUTION]

Replace rubber hoses for passage every two years. If and when fuel leakage is found, replace hose at once.

MAINTENANCE AND ADJUSTMENT

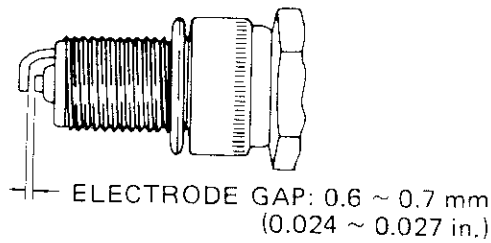

1. Cleaning and Adjusting Spark Plug

Recommended spark plug : NGK BM6A
CHAMPION CJ8

- If the plug contains carbon, remove it using plug cleaner or wire brush.
- Adjust the electrode gap to 0.6 ~ 0.7 mm (0.024 ~ 0.027 in.).

2. Cleaning Fuel Strainer

When the strainer is contaminated with dirt, remove it from the tank and wash in kerosene.

3. Carburetor

The carburetor greatly affects the operating conditions of the engine. Since it has been adjusted carefully at shop before shipment, avoid adjusting it unless absolutely necessary. If adjustments are needed, contact your nearest dealer.

4. Fuel Pipe

The rubber hose connecting the fuel strainer to carburetor may deteriorate and develop leaks after prolonged service. Therefore, this hose must be replaced every two years.

5. Cleaning Air Cleaner

The air cleaner is used for removing dust in the air so as to feed fresh air into the engine. If this cleaner element is seriously contaminated, start-up failure, poor output, and malfunctions of the engine may result, and also the service life of the engine will be shortened. Keep cleaner element always clean, according to the following procedures.

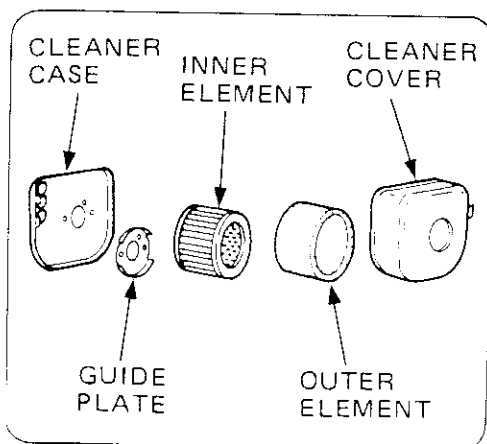

Cleaning Procedures:

- Take out the elements from the air cleaner.
- In kerosene, wash the inner element and outer element separately.
- After washing, saturate inner element and outer element in a mixture of 3 parts kerosene and 1 part engine oil.
- Squeeze out the mixture and install the elements.

6. Check each part for Loosen or Broken Bolts

- a) Tighten loose bolts.
- b) Check each part for fuel or oil leak.
- c) Replace broken or damaged parts with new ones.

7. Clean Cooling System

Grass, chaff or dirt may clog the recoil starter and the air cooling system after prolonged service.

Before each use, check the recoil starter and clean grass and debris if necessary.

Yearly or every 100 hours, whichever occurs first, remove the blower housing and cylinder baffle, clean the cooling fins to avoid overheating and engine damage.

6. PREPARATIONS FOR LONG STORAGE

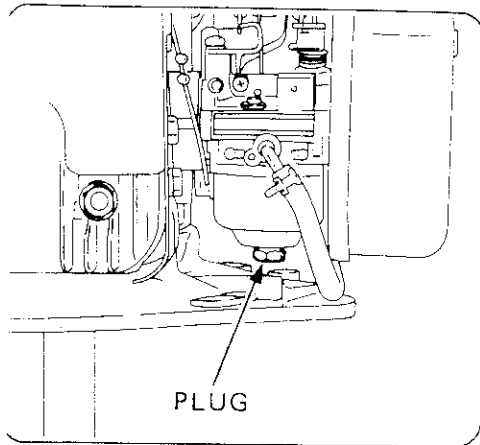

1. Drain the fuel tank and carburetor (by unscrewing the plug at the bottom of the float chamber).
2. Remove spark plug, and pour 5 ~ 10 cc of lubricating oil through the plug hole. Pull the recoil starter several times, and then, mount the spark plug.
3. Clean the engine outside with slightly oiled cloth.
4. Store in a clean, dry place.

7. SPECIFICATIONS

Model	EC13V	
Type	Air-Cooled, 2-Cycle, Single Cylinder, Vertical Take-off Shaft	
Direction of Rotation	Counterclockwise as viewed from Take-off Shaft Side	
Piston Displacement	123 ^{cc} (7.49 cu. in.)	
Fuel	Mixture Fuel (Gasoline 50: Lubricant 1) Recommended Lubricant: Exclusive 2-Cycle Engine Oil	
Fuel Tank Capacity	2 Liters (0.53 U.S. gallons)	
Spark Plug	NGK BM6A or CHAMPION CJ8	
Starting Method	Recoil Starter	
Dry Weight	11.2 kg (24.7 lbs.)	
Dimensions	Length	400 mm (15.7 in.)
	Width	334 mm (13.1 in.)
	Height	331 mm (13.0 in.)

- Optional Equipment: Engine Brake, Spark Plug Guard



 **FUJI HEAVY INDUSTRIES LTD.**

INDUSTRIAL PRODUCTS DIV.

Subaru Bldg.

1-7-2, Nishi-Shinjuku, Shinjuku-ku, Tokyo 160, Japan

PHONE ; (Tokyo 03) 3347-2420

FACSIMILE ; (Tokyo 03) 3347-2418